

Installation

ONE

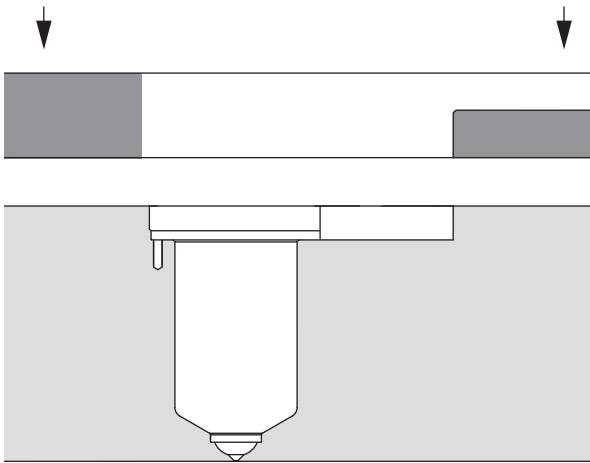

Place the **backplate** on top of the **cavity plate**

TWO

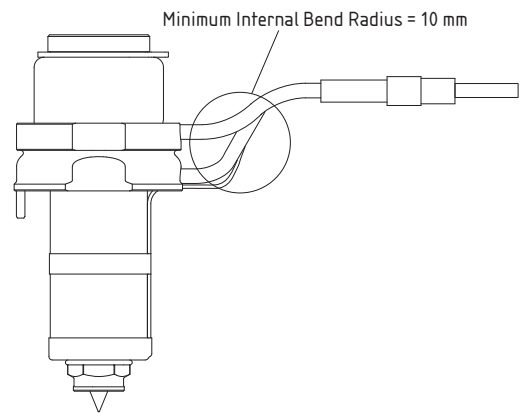

Carefully bend the **heater** and **T/C wires**.
DO NOT exceed the bend radius specified

THREE

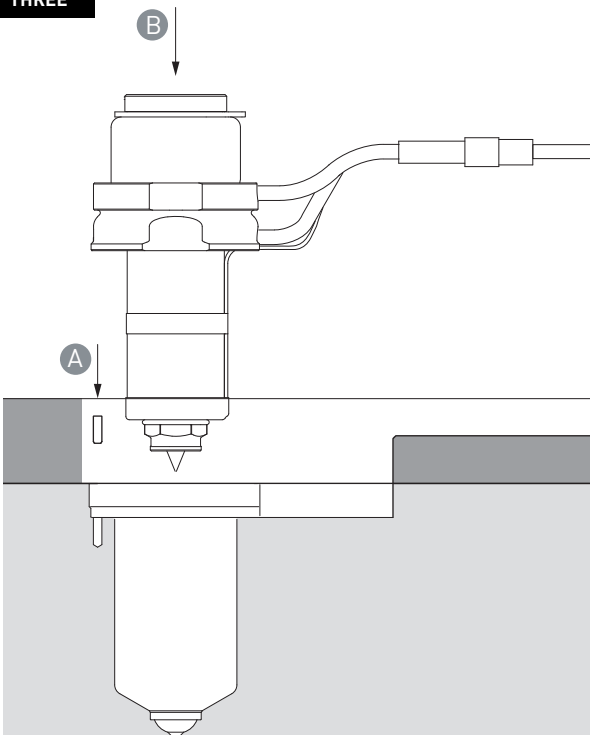

- A** Fit the **dowels** in the **dowel holes** in the **cavity plate**.
- B** Insert the **SX nozzle** into the cavity plate. It should be a slide fit

FOUR

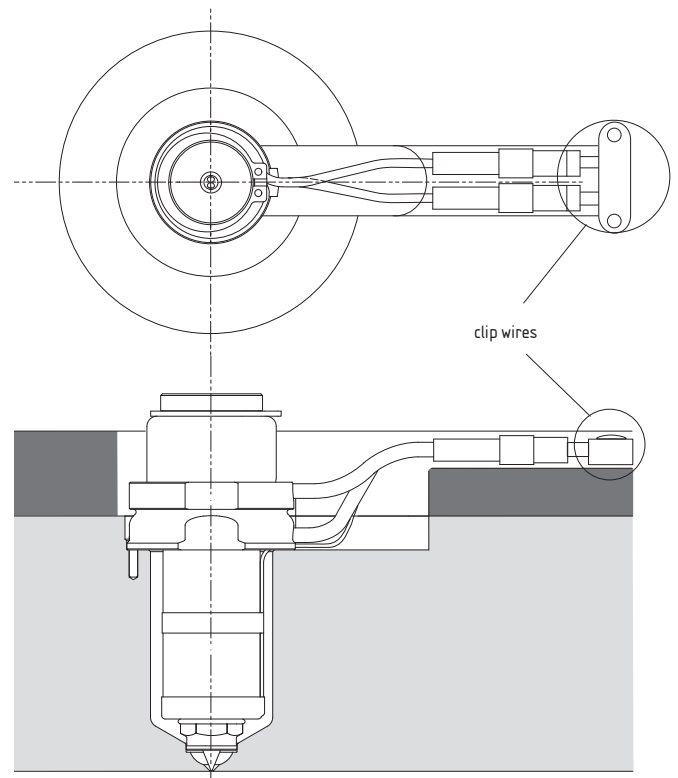

Attach **wire clips** over the **wires**.
DO NOT crush wires.