

## Single BX Nozzle Installation Guide

## ONE

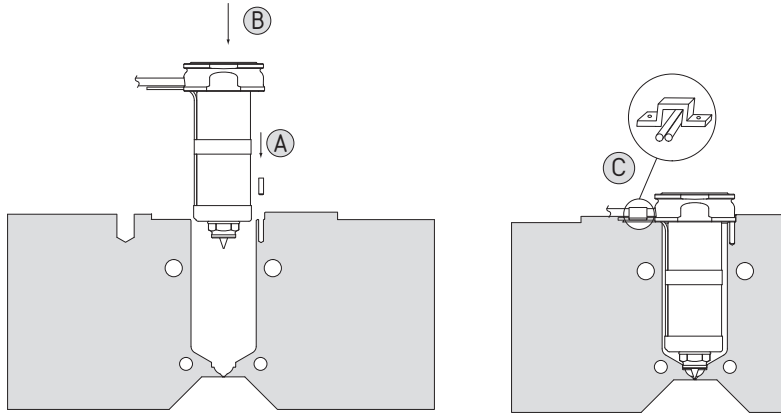

- (A) Fit the dowel in the dowel hole in the mould plate
- (B) Fit the nozzle into the mould plate
- (C) Clip the wires to the mould plate to ensure they are not pinched

## TWO

Check that contact with mould plates and locating ring is kept to a minimum

→ Refer to the checksheet on pg 2 to ensure the nozzle location dimensions are correct

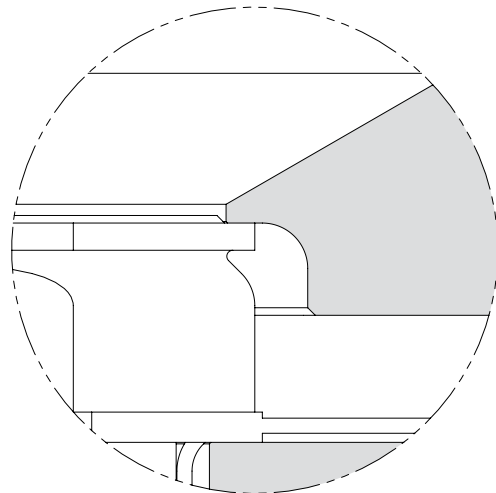
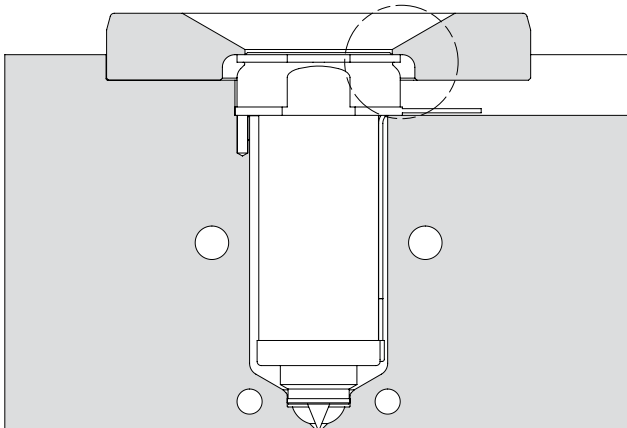

Note: Minimal contact between locating ring and nozzle.

**BX Thermal Gate Single Nozzle Installation Checksheet**

Project Details	
Distributor Name:	
Customer Name:	
Customer Reference #:	
Mastip Reference #:	
Date:	

Additional Information	
Material:	
Planned Nozzle Temp.:	
Planned Mould Temp.:	
Planned Manifold Temp.:	

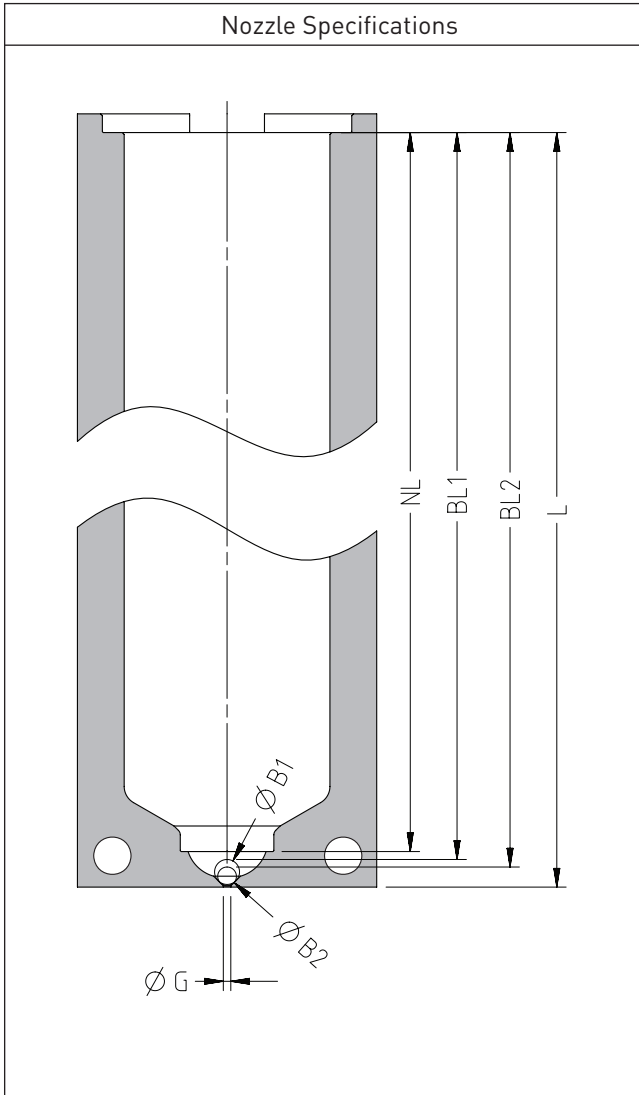

Cavity Dimensions					
Nozzle #	NL	BL1	BL2	L	G
1					

Ball Diameter (ØB)		
Nozzle	ØB1	ØB2
BX13	Ø3.00	Ø2.00
BX16	Ø4.00	Ø2.00
BX19	Ø4.00	Ø3.00
BX27	Ø6.00	Ø4.00