

METICOM CTI Series

Temperature & Sequential Valve Gate Controller

User Guide



WARRANTY

We warrant that this product will be free from defects in materials and workmanship for a period of two (2) years from the date of shipment. If any such product proves defective during this warranty period, we, at our option, either will repair the defective product without charge for parts and labor or will provide a replacement in exchange for the defective product.

This warranty shall not apply to any defect, failure or damage caused by improper use or improper or inadequate maintenance and care. We shall not be obligated to furnish service under this warranty; a) to repair damage resulting from attempts by personnel other than our representatives to repair or service the product; b) to repair damage resulting from improper use or connection to incompatible equipment; or c) to service a product that has been modified or integrated with other products when the effect of such modification or integration increases the time or difficulty of servicing the product.

This warranty excludes replacement of fuses, triac, calibration, contact points and damage to the module from the use of improper styles of fuses. The maximum allowable fuse rating is 15 amps. Lower ratings may be used for improved protection.

SAFETY

Our products have been designed to be safe and simple to operate. As with any electronic equipment, you must observe standard safety procedures to protect both yourself and the equipment.

- Read all the instructions before connecting power and turning on the system.
- Service and installation of this equipment should only be performed by qualified service personnel familiar with high voltage electrical circuits.
- All international and local electrical codes must be followed when connecting this equipment.
- Only persons with knowledge of the system's operation and capabilities should operate the system.
- Unless specifically explained in this manual or directed by us, do not attempt to repair the system yourself. Doing so could result in damage to the system, or serious personal injury.
- Do not apply voltage to a terminal that exceeds the range specified for that terminal.
- Do not connect thermocouples to any live areas of the heaters. Lock out and tag the controller and mold and make sure there is electrical insulation between the thermocouple and any live areas.
- Do not operate this product from a power source that applies more than the voltages specified.
- Do not operate this product with covers or panels removed. All unused slots of a main frame must be covered with the appropriately sized blank panels.
- Do not operate this product when wet.
- Do not operate this product in an explosive atmosphere.

CAUTIONS

- When turning on the system, you should turn on all circuit breakers before powering on the HMI. You may experience communication issues if you do not follow this sequence.
- After turning on the system ensure the fans are running.
- Never allow the fan inlets or outlets on the unit become blocked. If these become blocked insufficient airflow can cause damage to the system.
- When switching off the system, you must wait 30 seconds before switching on. You may experience communication issues if you do not follow this sequence.

Chapter 1 Introduction

1.1 CTI Series Mainframe Configuration

The CTI controller series is made up of 3 different models of mainframes depending on the number of zones required. These are referred to as CTI-100, CTI-200, and CTI-300.

All the mainframes utilize the same temperature control module CTI-M2, and the same sequential valve gate control module CTI-V2.

Access to all user serviceable parts, such as fuses, are done through the front of the controller by loosening the upper and lower screws on each heat sink and removing the modules.

The connectors for the mold-power and thermocouple cables, and the connectors for valve gate control cables, are located at the rear of the mainframe.

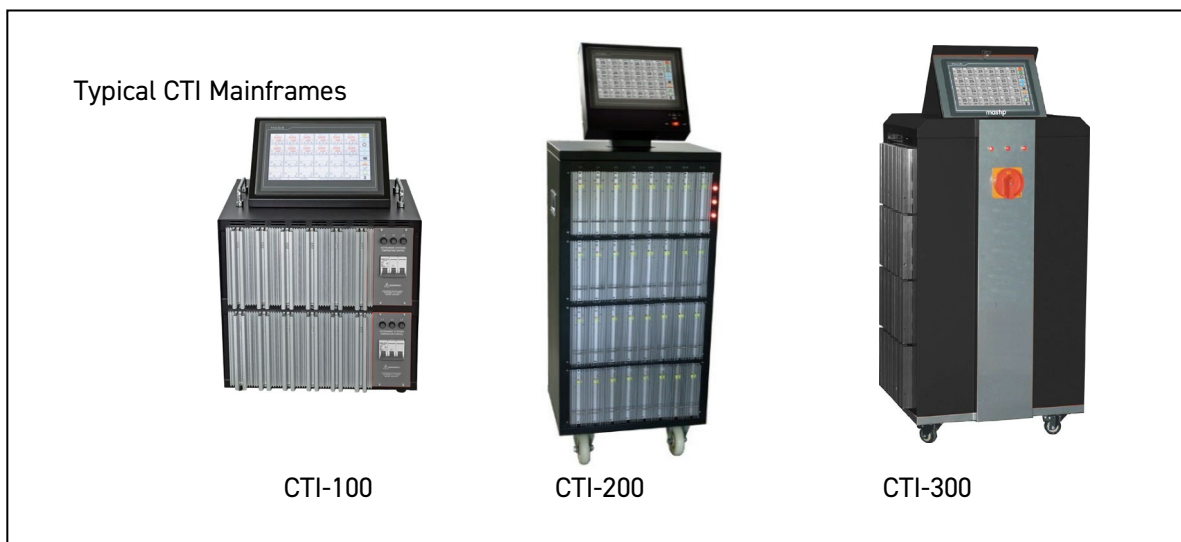

1.2 Control Modules

The mainframes are available with 2 styles of control modules depending on requirements. The

modules are fully interchangeable across all mainframe designs. The externally mounted heat sink and integrated design reduce maintenance cost and downtime.

Each CTI-M2 temperature control module comes standard with two zones at 15amps per zone. Each CTI-V2 sequential valve gate control module can control up to six valve gates each module. One or more power control modules are also required to supply power requirements to the system solenoid valves. The position and quantity of power control modules and valve gate control modules in the mainframe are configured depending on the initial specification request, and are fixed to the specific slot position.

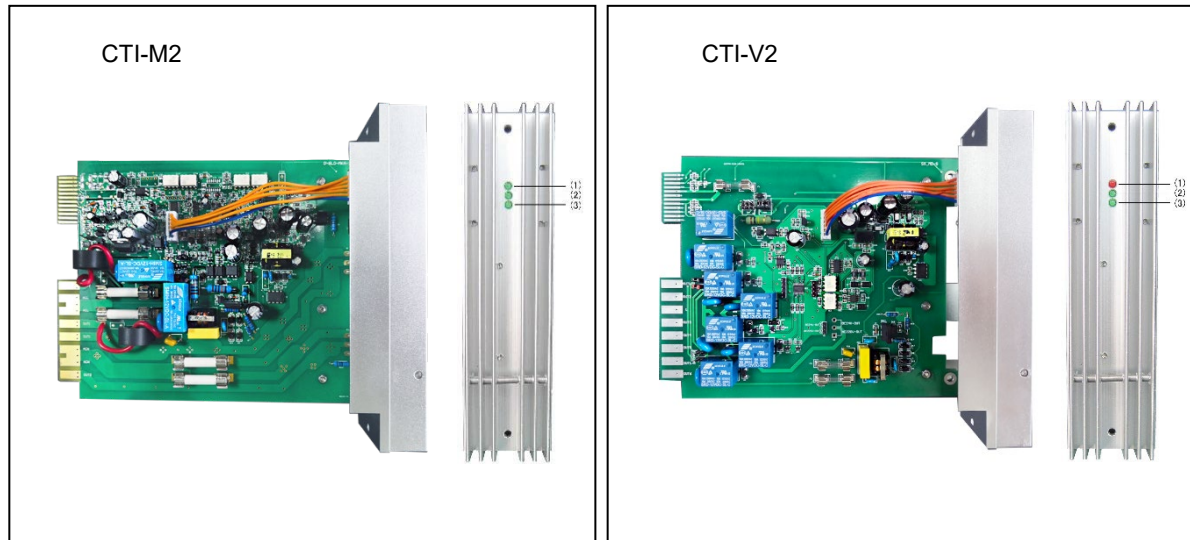

(1) Power indicator: **green** light when powered on.

(2)&(3) Zone A & Zone B status indicator:
green – stop; **red** – running;
 blink fast – communicating with HMI;
green / red alternately: alarm

(1) Power indicator.

(2) Injection signal indicator.

1.3 Specifications

Model	CTI-100	CTI-200	CTI-300
User Interface	Full color LCD touch screen		
Display Size	7.0" / 10.2"	10.2"	
Max. Total Zones	32	80	120
Max. Temp. Zones	32	80	120
Max. Sequential Zones	24	24	
Power Supply	3-Ph+E (4 wire) 200-240Vac		
	3-Ph+N+E (5 wire) 380-415Vac		
Working Conditions	0~55°C (32~131°F), 10~80%RH (No condensing)		

Storage Conditions	-20~70°C (-4~158°F), 10~80%RH (No condensing)		
Temperature Control			
Control Mode	Auto-PID / Manual	Measurement Range	0~500°C (32~932°F)
Output Control	Zero Cross / Phase Angle	Setting Range	0~450°C (32~842°F)
Thermocouple	J or K-Type, software selectable	Temperature Unit	°F or °C, software selectable
Calibration Accuracy	±0.25% FS	Control Stability	±1 digit under steady state
Load Capacity	Rated 240Vac, 15A/zone	Overload Protection	Fuses on both heater legs
TC Connector	Various options available	Soft-Start	Uses low voltage for heater dehumidification
Mold Power Connector	Various options available		
Sequential Valve Gate Control			
Trigger Signal	DC24V or Dry contact	Trigger Mode	4 modes selectable
Screw Position Signal	DC 0~10V	Screw Position Unit	mm or inch
Control Mode	Auto / Manual	Time Resolution	1s, or 0.1s, or 0.01s
Output Signal	DC24V, or AC220V or Relay contact	Output Connector	Various options available

1.4 Features

Cabinet	HMI
Temperature only, Sequential Valve Gate only, or Combination of both	Full color LCD touch screen
Max. 120 zones	English/Spanish/Chinese
CE compliant	Fixed on mainframe or Stand-alone
Control Modules	Alarms & Protection
Control module	Thermocouple broken /reversed /shorted
2-zone per temperature module (15 Amp per zone)	Heater broken /shorted /oversize
6-gate per Sequential Valve Gate module	Temperature high / low
Other Functions	Fuse blown
Stopping system remotely (optional)	Heating invalid
Standby system remotely (optional)	Triac breakdown
All zones' temperature in tolerance output (optional)	Power supply over-voltage
Start sequence in group	Cabinet temperature over-setting
Sensor fault solution	Alarm output (optional)

1.5 Typical Power and Thermocouple Output Connector Wiring

The system can be supplied with either European style or US style power and thermocouple mold connectors, typically wired as follows (custom wiring available)

Separate Power & Thermocouple Connectors (European style 24 pin series "E")

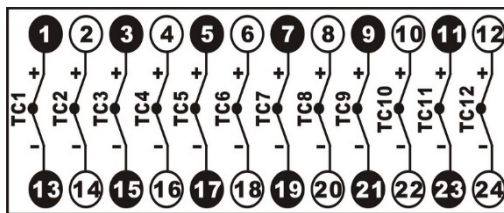
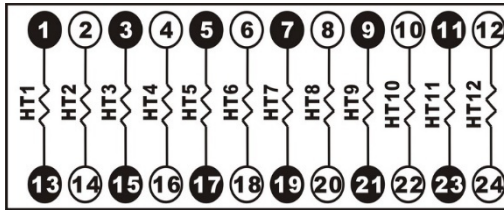

Separate Power & Thermocouple Connectors (US style 25 pin series "A")

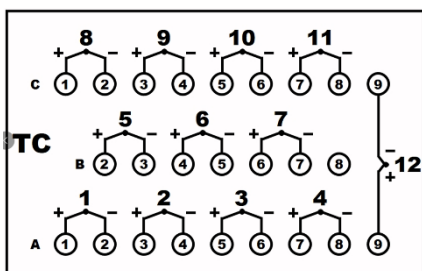
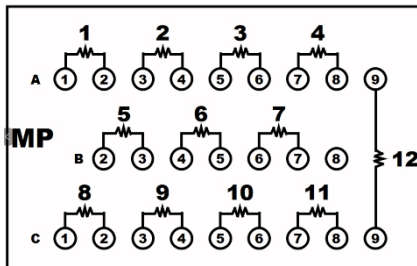

1.6 Sequential Valve Gate Trigger & Output Connectors Wiring

The valve gate sequence can be started by either a 24Vdc Trigger Input from the injection molding machine start cycle, or by a 0-10Vdc Screw Position source from the injection molding machine.

Valve Gate Input Wiring

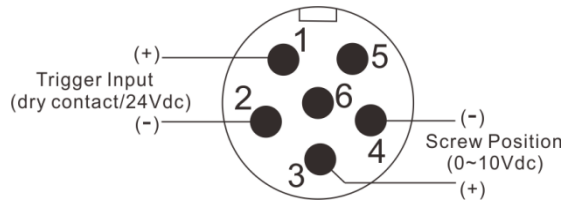

Signal	Pins	Description	Type
Trigger Input	1 & 2	Sees a closed condition or DC24V as a signal to start the timer on the valve sequence	Normally Open Dry Contact Or DC24V
Screw Position	3 & 4	Accepts a voltage source input that relates to the main screw position. A calibration routine within the controller adjusts actual input to actual screw position.	0 to 10 Volts

Valve Gate Output Wiring (European style 24 pin series "A")

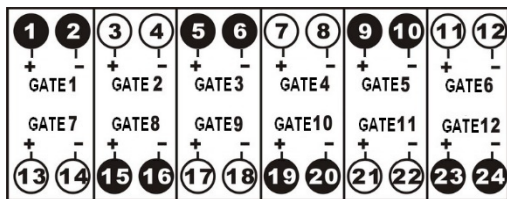

Power Input Wiring

The CTI temperature controllers can be connected to either 3-phase 4-wire Y / Δ type (200-240Vac) or 3-phase 5-wire Y type (380-415Vac) mains power supplies.

3-Ph+N+E (5 wire) 380-415Vac

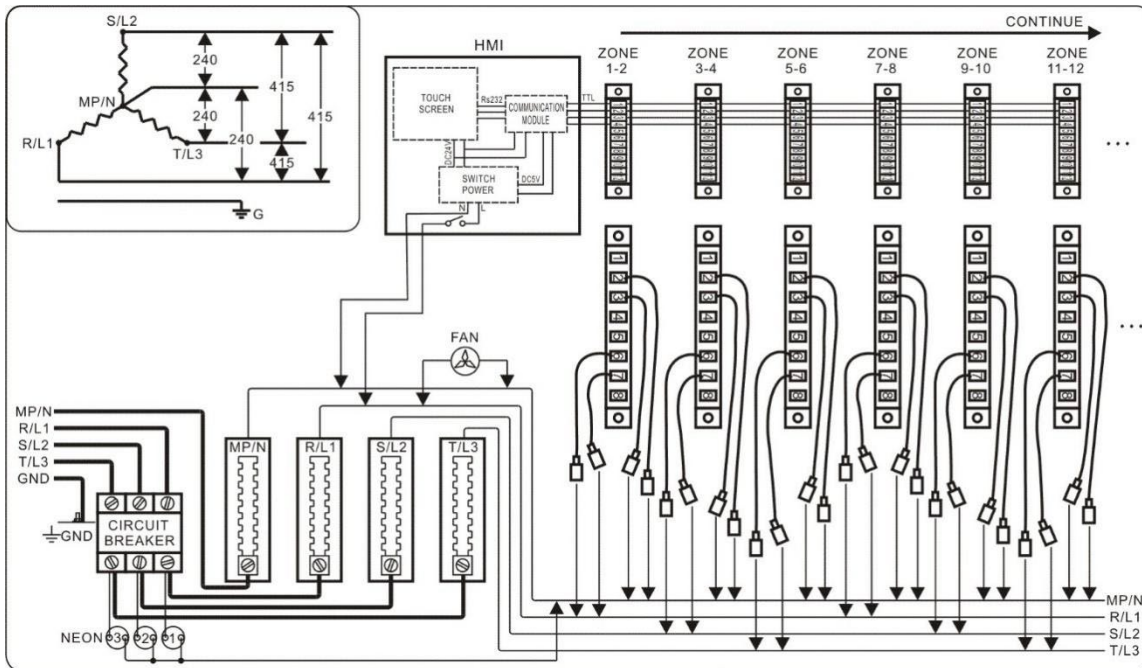

3-Ph+E (4 wire) 200-240Vac

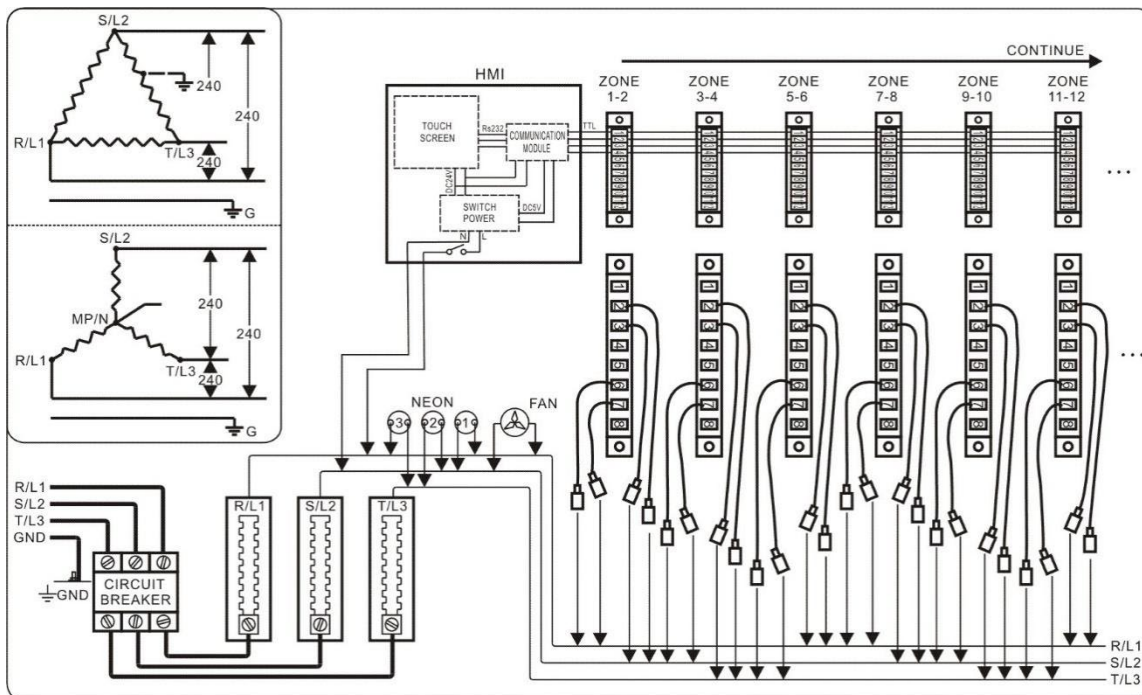

1.7 Remote Input & Alarm Output Connectors Wiring

(Where specified)

Remote Input Wiring

Alarm & Normal Output Wiring

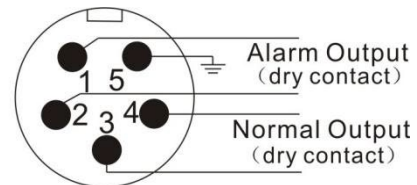
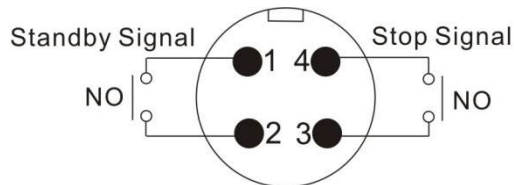

Signal	Pins	Description	Type
Standby Signal	1 & 2	After a delay time (adjustable) since the contact is closed, the controller will work in standby mode until AUTO button is pressed on HMI.	Normally open dry contact
Stop Signal	3 & 4	When the contact is closed, the controller will stop running, same as pressing STOP button on HMI.	Normally open dry contact
Alarm Output	1 & 2	Contact is closed when any alarm happens, and it will be reset by silence button on the alarm history page.	Normally open dry contact 1A/250Vac
Normal Output	3 & 4	Contact is closed when all zones' temperature are in normal output tolerance.	Normally open dry contact 1A/250Vac

Chapter 2 Inspection & Installation

2.1 Unpacking and Inspection

1. After unpacking, inspect the mainframe and check for any damage that may have occurred during shipment.
2. Check the circuit breaker disconnect and neon phase voltage indicators for damage.
3. Check for proper operation of circuit breaker with no voltage applied.
4. Check connectors for any physical damage.
5. Check AC input power configuration matches the local power supply. The power specification label is located on the back cover of the mainframe's power input terminal block. The label indicates the input voltage configuration that was prewired at the factory.
6. Inspect the HMI and check for any damage that may have occurred during shipment.

7. Check power connector/cable and communication connector/cable of HMI for any physical damage.

2.2 Mounting the HMI (only CTI-200 Series)

1. Connect the HMI's power cable and communication cable to corresponding plug on the mainframe.
2. Mount the HMI on the mainframe by screws provided.

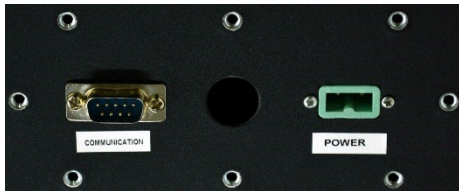

2.3 Connecting the HMI (Standalone HMI only)

1. Place or mount the HMI on the position required.
2. Connect the HMI and the mainframe with communication cable.



2.4 Connecting the Power Input Cable (CTI-200 / CTI-300)

1. Ensure the power input cable meets the international and local electrical code specifications.
2. Remove the metal cover of the power input terminal block by removing screws around its perimeter.
3. Remove the plastic panel of the terminal block.
4. Insert power input cable through access hole provided on the cover.
5. Connect AC input cord to the input terminal block as shown on the inner side of cover, according to the input voltage configuration you are attaching to.
6. Connect the earth cord to the ground terminal beside the input terminal block.
7. Cover the plastic panel on the terminal block.
8. Take up excess slack in cable and secure with strain relief clamp.
9. Mount the metal cover of the power input terminal block on the mainframe.



(1)



(2)



(3)



(4)



(5)

CAUTIONS!

Service and installation of this equipment should only be performed by qualified service personnel familiar with high voltage electrical circuits.

All international and local electrical codes must be followed when connecting this equipment.

Use O-type (ring) terminals on the power input cord connected to the terminal block.

Do not apply power to this cable or the unit when the back terminal block cover is removed.

Do not connect the power input cord to your power distribution system until the back terminal block cover is securely in place.

Ensure the chassis has been earth grounded before applying power.

Chapter 3 Connecting the System to the Mold

3.1 Prior to Start Up

- Check that the system is completely disconnected from the power source.
- Clean up any water, oil, dirt, cleaning fluids etc. that may have spilled during a mold change or since the last production run.
- Check all the cable connections between the system and the mold. Make sure all the cables are free from wear or damage.
- Check that the earth/ground connection is in good condition. Verify the system and the mold have the same ground reference.
- Check the output power and thermocouple wiring configuration on the mainframe and cable is the same as on the mold.
- Confirm that the sequential valve gate power output meets the requirement of the solenoid valves.
- Confirm that the sequential valve gate trigger signal meets the requirement of the controller.

3.2 Verifying the Connection

1. Connect the mold power and thermocouple cables.
2. Connect the sequential trigger signal cable and output cable (if required).
3. Using an Ohmmeter, touch one test lead to the mold and the other to the mold ground terminal on the system. Resistance must be less than 1Ω .
4. Check all the circuit breakers and make sure they are in the OFF position prior to connection of the controller to the power source.

3.3 Startup Procedure Checklist

1. Connect the mold power and thermocouple cables, sequential control cables between the mold and controller (if required).
2. Connect the controller to the power source.
3. Switch the circuit breakers ON.
4. Turn on the HMI, then select the language.
5. Log in the system (if required).
6. Load a mold setup (if required).
7. Checking the mold setup zone by zone on HMI.

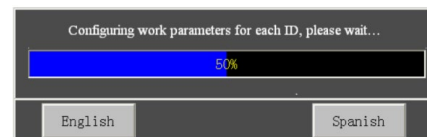

8. Correct any faults found during diagnostics.
9. Touch “Run” to start the system.
10. Check that the controller is functioning correctly.

IMPORTANT!

When switching off the system, wait 30 seconds before switching on again. System communication issues can be experienced if the system is turned off and on incorrectly.

Chapter 4 Operator Interface

4.1 Main Interface

The main interface is used to monitor, log in the system and general operations.

4.1.1 Temperature Control

Icon Button Mode, 24-zone per page, Resolution 0.1 is not checked

1 zone1 Stop 32 sv: 200 °C 0 % 0 A J	2 zone2 Stop 32 sv: 200 °C 0 % 0 A J	3 zone3 Stop 32 sv: 200 °C 0 % 0 A J	4 zone4 Stop 32 sv: 200 °C 0 % 0 A J	5 zone5 Stop 32 sv: 200 °C 0 % 0 A J	6 zone6 Stop 32 sv: 200 °C 0 % 0 A J	 	
7 zone7 Stop 32 sv: 200 °C 0 % 0 A J	8 zone8 Stop 32 sv: 200 °C 0 % 0 A J	9 zone9 Stop 32 sv: 200 °C 0 % 0 A J	10 zone10 Stop 32 sv: 200 °C 0 % 0 A J	11 zone11 Stop 32 sv: 200 °C 0 % 0 A J	12 zone12 Stop 32 sv: 200 °C 0 % 0 A J		
13 zone13 Stop 32 sv: 200 °C 0 % 0 A J	14 zone14 Stop 32 sv: 200 °C 0 % 0 A J	15 zone15 Stop 32 sv: 200 °C 0 % 0 A J	16 zone16 Stop 32 sv: 200 °C 0 % 0 A J	17 zone17 Stop 32 sv: 200 °C 0 % 0 A J	18 zone18 Stop 32 sv: 200 °C 0 % 0 A J		
19 zone19 Stop 32 sv: 200 °C 0 % 0 A J	20 zone20 Stop 32 sv: 200 °C 0 % 0 A J	21 zone21 Stop 32 sv: 200 °C 0 % 0 A J	22 zone22 Stop 32 sv: 200 °C 0 % 0 A J	23 zone23 Stop 32 sv: 200 °C 0 % 0 A J	24 zone24 Stop 32 sv: 200 °C 0 % 0 A J		
Pattern name:b		No Alarm		A:229V	B:229V	C:229V	2021/09/13 15:49:27

Icon Button Mode, 42-zone per page, Resolution 0.1 is checked

1 Stop PV: 30.0 SV: 200 °C	2 Stop PV: 30.0 SV: 200 °C	3 Stop PV: 30.0 SV: 200 °C	4 Stop PV: 30.0 SV: 200 °C	5 Stop PV: 30.0 SV: 200 °C	6 Stop PV: 30.0 SV: 200 °C	 	
7 Stop PV: 30.0 SV: 200 °C	8 Stop PV: 30.0 SV: 200 °C	9 Stop PV: 30.0 SV: 200 °C	10 Stop PV: 30.0 SV: 200 °C	11 Stop PV: 30.0 SV: 200 °C	12 Stop PV: 30.0 SV: 200 °C		
13 Stop PV: 30.0 SV: 200 °C	14 Stop PV: 30.0 SV: 200 °C	15 Stop PV: 30.0 SV: 200 °C	16 Stop PV: 30.0 SV: 200 °C	17 Stop PV: 30.0 SV: 200 °C	18 Stop PV: 30.0 SV: 200 °C		
19 Stop PV: 30.0 SV: 200 °C	20 Stop PV: 30.0 SV: 200 °C	21 Stop PV: 30.0 SV: 200 °C	22 Stop PV: 30.0 SV: 200 °C	23 Stop PV: 30.0 SV: 200 °C	24 Stop PV: 30.0 SV: 200 °C		
25 Stop PV: 30.0 SV: 200 °C	26 Stop PV: 30.0 SV: 200 °C	27 Stop PV: 30.0 SV: 200 °C	28 Stop PV: 30.0 SV: 200 °C	29 Stop PV: 30.0 SV: 200 °C	30 Stop PV: 30.0 SV: 200 °C		
31 Stop PV: 30.0 SV: 200 °C	32 Stop PV: 30.0 SV: 200 °C	33 Stop PV: 30.0 SV: 200 °C	34 Stop PV: 30.0 SV: 200 °C	35 Stop PV: 30.0 SV: 200 °C	36 Stop PV: 30.0 SV: 200 °C		
37 Stop PV: 30.0 SV: 200 °C	38 Stop PV: 30.0 SV: 200 °C	39 Stop PV: 30.0 SV: 200 °C	40 Stop PV: 30.0 SV: 200 °C	41 Stop PV: 30.0 SV: 200 °C	42 Stop PV: 30.0 SV: 200 °C		
Pattern name:b		No Alarm		A:229V	B:229V	C:229V	2021/09/13 15:49:27

- **Function Button:** Icon mode is the default setting. Text mode can be selected on system setting page.

- **24 or 42 zones per page:** 24-zone is the default setting, but can be changed on system setting page.

- **Resolution:** 1 is the default setting, 0.1 can be selected on system setting page.

 **[Run]:** (green) Run selected zones or all zones of temperature & valve (if no zones selected)



 **[Stop]:** (red) Stop selected zones or all zones of temperature & valve (if no zones selected)

 **[Auto]:** Place all zones or selected zones run in Auto mode

 **[Standby]** Place all zones or selected temperature zones in Standby mode. In standby mode, the control target value is 70% of set value

Note: Currently display set value remains the same

 **[PgUp]:** Used to view the previous page

 **[PgDn]:** Used to view the next page
On the last page, you will see  **[SVG]**

 **[SVG]:** Shift to the sequence valve gate control interface

 **[Alarm]:** Used to view the alarm record

 **[Group]:** Enter the group parameter setting, pattern/mold files management, and language selected

 **[Setting]:** Used to enter the system setting and working mode setting interface

 **[Login]** / **[Logout]:** Used to log in/out the system to achieve the different authority

Note:  **[Graph]:** This icon has been transferred to Group Setting Interface.

4.1.2 Temperature Zone Introduction

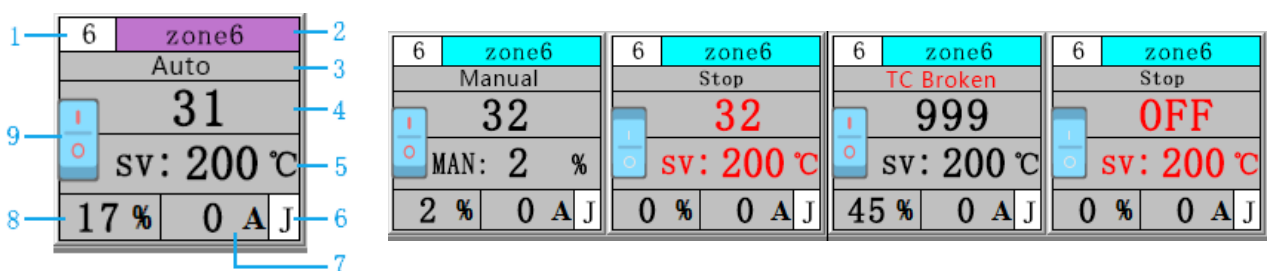

1. **Zone number:** Current temperature zone ID number, cannot be modified.

2. **Zone name:** Current temperature ID name can be customized, default background is blue. This temperature zone name customization need supervisor or above authority. For operation mode see 6.5.3.

3. **Zone status:** Auto, Manual, Standby, Stop, Alarm(display in red)

4. **Actual Temperature (PV):**

- resolution 0.1 can be selected on system setting page.

- displayed in **red** color in stop state
- if thermocouple is open, 999 will be displayed
- if zone is turned off, **OFF** is displayed in red color
- blinking when communication fails
- click it to set zone's parameters and operate it

5. Setpoint (SV):

- temperature unit can be selected between Celsius and Fahrenheit by Engineer's parameter.
- displayed in **red** color in stop state
- output percent setting will be displayed in manual mode
- click setting value, output percent and load current can be alternated to show in 42-zone page

6. **Sensor type:** can select J-type and K-type in zone setting or group setting

7. **Load current:** display current real- time output current value

8. **Power output percentage:** display the current real-time power output percentage

9. **Temperature zone Run/Stop button:** run and stop a single temperature zone directly

4.1.3 Multiple Temperature Zone Selection

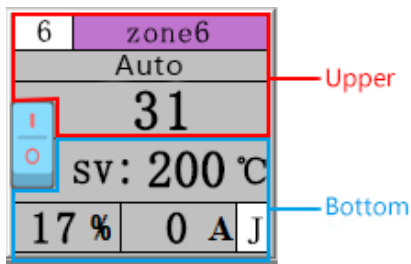

Click different sections of the temperature zone for different actions.









Section 1: Click the upper half part of the zone to enter temperature zone setting











Section 2: • Click the bottom half part of the zone to select current zone (zone blinking).

- Click again to cancel selection
- Select multi zones to execute group operation of Run/Stop/Auto/Standby
- Select to execute group operation (modify general parameters)

Note: The selected zone will keep blinking if no operation or parameters are entered

4.1.4 Sequence Valve Gate Control

1	GATE1	2	GATE2	3	GATE3	4	GATE4	5	GATE5	6	GATE6	    Test     				
7	GATE7	8	GATE8	9	GATE9	10	GATE10	11	GATE11	12	GATE12					
13	GATE13	14	GATE14	15	GATE15	16	GATE16	17	GATE17	18	GATE18					
19	GATE19	20	GATE20	21	GATE21	22	GATE22	23	GATE23	24	GATE24					
Pattern name:b												No Alarm	A:229V	B:229V	C:229V	2021/09/13 15:49:27

-  **[Stop]**: (red) Stop valve gate control of all zones
-  **[Run]**: (green) Run all zones of temperature & valve
-  **[Stop]**: (red) Stop all zones of temperature & valve
- [Auto]** / **[Manual]**: Place the sequence valve gate control of all zones in Auto/Manual mode.
-   Each gate can be opened or closed manually, (usually used for system debugging).
-  **[Temp]**: Shift to the temperature control interface
- TEST** **[TEST]**: Used to reverse valve gate status (open/closed) under manual mode
-  **[Graph]**: Used to preview the open & close sequence setting of all gates (only time parameters)
-  **[Alarm]**: Used to view the alarm record
-  **[Group]**: Enter the group/global setting, pattern/mold files management, and language selection
-  **[Setting]**: Used to enter system setting
-  **[Login]** / **[Logout]**: Used to log in/out the system to achieve the different authority.

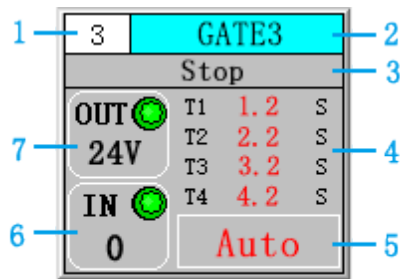

1. **Gate Number:** Current valve ID number, (cannot be modified)

2. **Gate Name:** Current valve ID name

3. **Gate Status:** Running, Manual or Close

4. **Gate Setting value:** All segments are displayed in red color and executed segment will turn black

5. **Control mode:** Auto, Manual , OFF

6. **Input signal lamp and Screw position:** screw position unit can be mm or inch, select in screw position calibration

7. **Output signal lamp and output type:** DC24V or AC 220V

Note: For lamps in 6/7, no signal shows green lamp; signal generated shows red lamp.

4.2 USB Port

The USB port on the CTI series is intended to be used to copy mold setup files to and from the system. The screen for importing or exporting mold setups is displayed in the Group Setup Screen.

These mold setup files can be copied to other CTI controllers that support the same file type.

The USB port is also be used to export the historical data record (in csv format) from the system. The screen for exporting data record is displayed in the History Data Curve Screen.

CAUTION!

Never power on the unit with a device in the USB port.

Never connect a powered USB hub or other device to the USB port.

Removing the USB disk from the system during a read or write operation could cause data corruption to the USB disk contents that could result in bad files or prevent the entire drive from being usable.

The following warnings and restrictions should be observed when using the USB port:

Only supports USB disks that use a File Allocation Table (FAT or FAT32) format.

Only supports USB versions 2.0 and 1.1.

Use an empty USB disk or one that contain as few files as possible.

Chapter 5 Security & System Setting

5.1 Login / Logout the System

To avoid accidental changes and protect the system data, the controller is set up with different operator levels which have different security authorities.

To achieve the corresponding authority, the operator should login the system by their security group name and password before operation.

5.1.1 Login / Logout the System

- The main interface displays  [Login] when no user login. Click the icon and enter the Login interface, select the corresponding user name and input password to login the system.

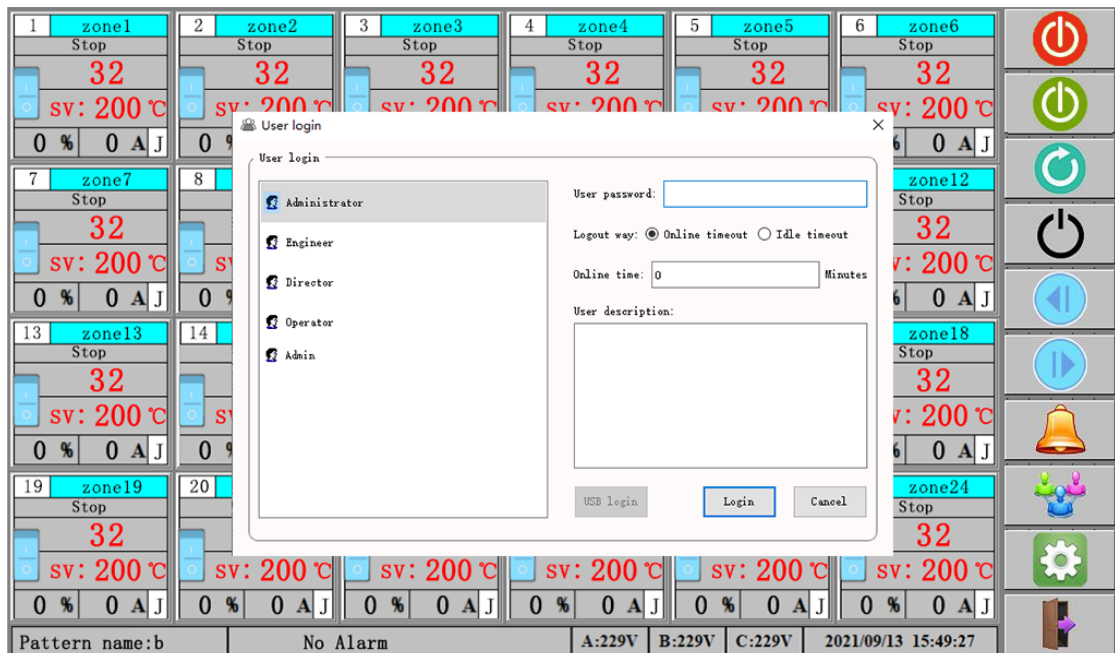

- Set timeout system logout automatically. After inputting password, you can choose Logout type, "Online timeout" and "Idle timeout". You can set the time, for example: "Idle timeout" with 10 minutes. If no any operation after 10 minutes, the system will turn to be non-login status.

- The main interface displays  **[Logout]** when user login. You can click the icon and choose **[Yes]** to logout the system.

5.1.2 User's Authorities List

User Group	Authorities	Remarks
Non-Login	<ul style="list-style-type: none"> • View data only, can't operate • Visit alarm records 	
Operators	<ul style="list-style-type: none"> • All authorities of Non-Login • Modify temperature setting value • View module types and status • Set system time and date • Modify password • View help interface • Select display resolution etc. • Select 24/42 page display 	<p>User name: "Operator"</p> <p>Initial password: "1"</p>

Engineers	<ul style="list-style-type: none"> ● All authorities of Operators ● Manage all operator users ● Modify all parameters of all zones ● Select language, English / Spanish ● Pattern management ● Set manual mode if necessary ● View system operation records ● Set thermocouple fault solution ● Set data storage interval time ● Operate alarm silencing ● View history curve, export data 	<p>User name: "Engineer"</p> <p>Initial password: "321"</p>
Director	<ul style="list-style-type: none"> ● All authorities of Engineers. ● Manage operator and engineer users ● Modify zone id, set zone color ● Open / close zone ● PID auto-tuning, Boost ● Clear data records ● Set auxiliary functions 	<p>User name: "Director"</p> <p>Initial password: "654321"</p>
Admin	<ul style="list-style-type: none"> ● All authorities of director ● Manage operator, engineer, director users ● Select OAID display, for maintenance 	<p>User name: "Admin"</p> <p>Initial password: "87654321"</p>
Super Admin	<ul style="list-style-type: none"> ● All authorities of admin ● Manage all users 	<p>User name: "Administrator"</p> <p>Password kept by seller</p>

5.2 System Setting

Touch  [System] on the main interface of temperature control, then enter the System Setting Screen.

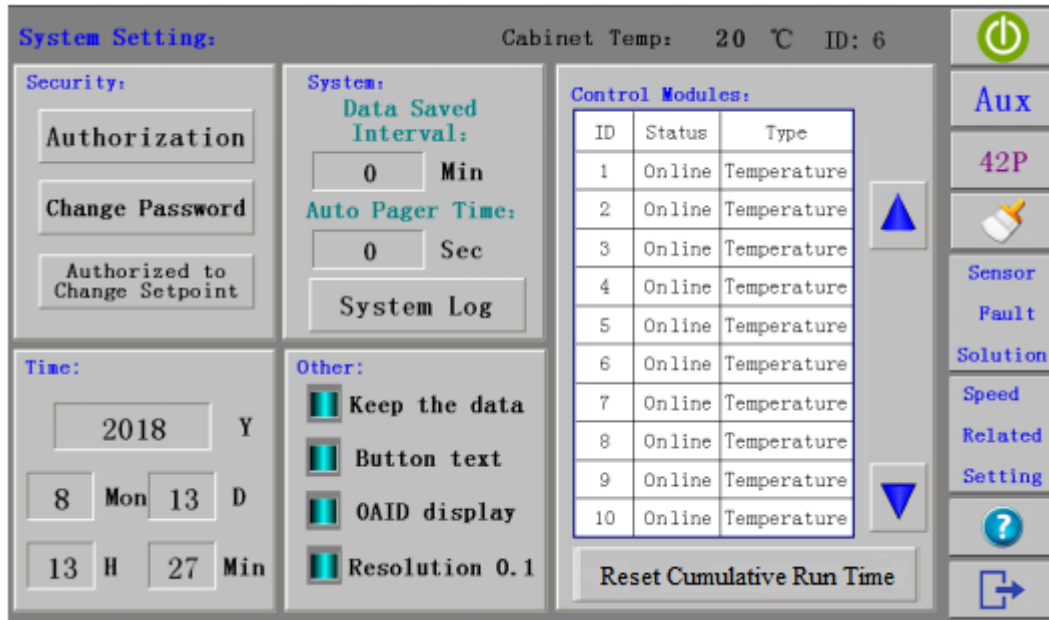

5.2.1 Security

- **Authorization:**

You can manage the users, include add, copy, and delete user.

You can also check the user's properties.

The user group name can be edited.

There are 4 User Groups: Operators, Engineers, Directors and Administrators.

Each group has different authorities, you can create more than one user in each group.

Operator: Authorized to use the functions related to production process.

Engineer: Authorized to use all functions except auxiliary functions

Director: Authorized to use all functions except OAID display for maintenance

Admin: All authorities (admin cannot be deleted)

- **Change Password:** You can change the password for the current user.

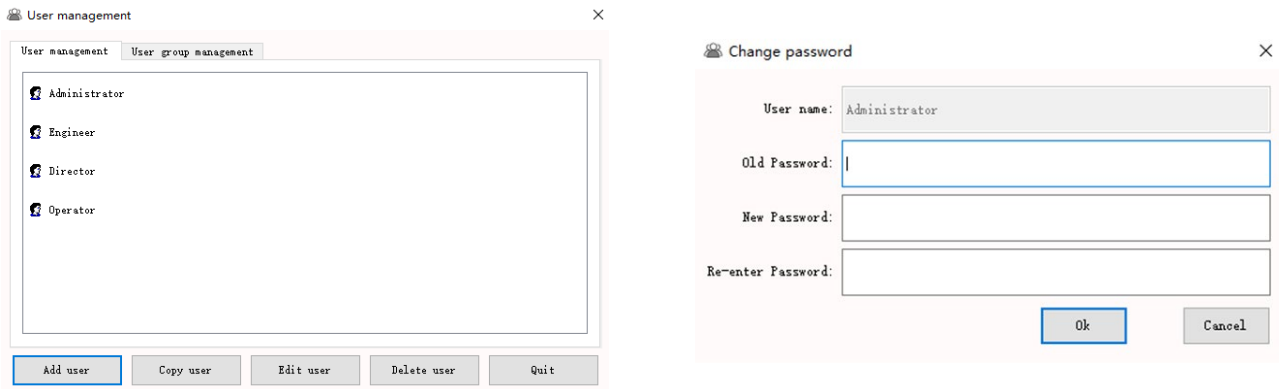

- **Authorized to Change Setpoint / Everyone Can Change Setpoint:**

Touch it to change the authority setting for operators login.

Display **Authorized to Change Setpoint:**

Current setting is Everyone Can Change Setpoint.

Operators not logged in the system can run/stop the system and change the setpoint.

Display **Everyone Can Change Setpoint:**

Current setting is Authorized to Change Setpoint.

Only the operator's login to the system can run/stop the system and change the setpoint.

5.2.2 Time

For the system time initialization, the setting method is:

- 1) Click the parameter you wish to set, then input the value on the screen keyboard.
- 2) Click the **[OK]** to finish the modification.

NOTE: If there is no response after you click the parameter values, it indicates that this parameter cannot be modified.

5.2.3 Cabinet Temperature & ID

Display the current max. cold-junction temperature (ambient temperature in the cabinet) of all modules, and its zone number.

5.2.4 System

- **Data Saved Interval:** After the setting time, the system saves the data automatically.

0 min. means not to save the data, and you cannot see the history curve.

- **Auto Pager Time:** After the setting time, main interface displays the next page automatically.
0 sec. means not to auto pager.
- **System Log:** By clicking it, you can check the system operation log.

System operation log:

SN	Time	Operation	Operator
1	2017-04-06 16:01:04	System is powered on, start to run.	Not Login.

Config

Quit

5.2.5 Other (blue – unchecked, green – checked)

- **Keep the data:** Zones' work state (Auto or Manual, and power output % in manual mode) will be the same as previous when the system re-started.
- **Button text:** Function Buttons will display by TEXT mode instead of ICON mode.
- **OAID display:** Zone's original ID displayed, used for maintenance.
- **Resolution 0.1:** Present temperature's display resolution is 0.1.

5.2.6 Control Modules

Display the communication status of each module and its type.

- **Reset Cumulative Run Time:** used for remote communication.

5.2.7 Auxiliary Functions (blue – unchecked, green – checked)

Touch **Aux** to enter Aux-function configuration page.

- **Appointed zone's number:**
The power supply voltage will be displayed in status bar on main interface.

- **Over voltage halt:**

When the power supply over voltage alarm is triggered the system will stop running.

- **Remote stop control:**

When the system receives an external stop signal it will stop running.

- **Remote standby control & Standby (delay) time:**

After the system receives an external standby signal it will work in standby mode until AUTO button is pressed on HMI.

- **Mold Self-inspection**

You can do self-inspection on multiple heating zones of the mold one by one before working. Set the start ID and end ID (maximum 96) to determine the scope of the self-inspection. Set the maximum operating temperature to limit the temperature rise and prevent accidents. After self-inspection, 10 kinds of faults can be shown (such as heater disconnection, heater short circuit, sensor reverse connection, sensor shortage, etc.) to prompt the user to correct the issue. Please contact the manufacturer for more information.

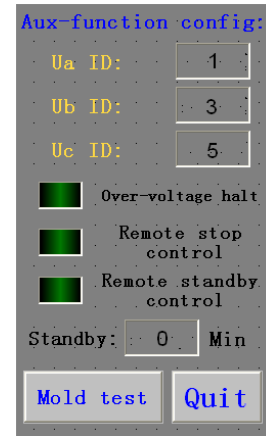

ID	Watt	Heat ID	SensorID	Status	Fault	Start ID
1	NO	1	0	NO	NO	1
2	NO	2	0	NO	NO	
3	NO	3	0	NO	NO	
4	NO	4	0	NO	NO	
5	NO	5	0	NO	NO	End ID
6	NO	6	0	NO	NO	20
7	NO	7	0	NO	NO	
8	NO	8	0	NO	NO	
9	NO	9	0	NO	NO	Maximum operating temperature
10	NO	10	0	NO	NO	0
11	NO	11	0	NO	NO	
12	NO	12	0	NO	NO	
13	NO	13	0	NO	NO	
14	NO	14	0	NO	NO	Run
15	NO	15	0	NO	NO	
16	NO	16	0	NO	NO	
17	NO	17	0	NO	NO	
18	NO	18	0	NO	NO	
19	NO	19	0	NO	NO	
20	NO	20	0	NO	NO	

when not in voltage regulation modeU
Die self check stop.
2021/10/13 16:43:31

- **Alarm Output Setting**

For 14 common faults (sensor disconnection, heater short circuit, heater overload, etc.), customers can choose to connect some or all the faults to an external alarm output. When the selected fault occurs, the system will give a relay output signal to drive an external alarm device.

● Auto-Manual Shifting



When this function is selected, the system will automatically switch to manual control mode once the sensor is disconnected. And the steady-state output value before disconnection will be used as the initial value of the manual output value.

Target sampling error range: for example, when SV= 200°C, the error range value is set to ±5, then the actual measured temperature (PV) is between 195–205°C. In this way, the output can be called steady-state output, and it can be used as the initial value of the manual output value.

● IoT Communication Protocol Selection

Three communication protocols can be selected, MODBUS-TCP/IP, MQTT, OPC-UA. It can remotely read system working status and working parameters, support remote start/stop system and single-segment start and stop, and support remote modification of temperature setting value.

5.2.8 42-zone / 24-zone Display in One Page

Touch   to alternate between 24-zone and 42-zone displayed in one page.

5.2.9 Clear Operation Log & Historical Data

Touch  **[Clear]** to clear all operation logs and all historical curve data.

5.2.10 Sensor Fault Solution

In case of a sensor failure you can appoint a zone as another zone's sensor reference to allow you to finish the production run. Typically, the sensors of these two zones are near and of the same watt as each other, such as 2 similar hot runner nozzles.



When the sensor of the zone (Major ID) fails the controller will use the temperature of the other zone (Related ID) to simulate the failed one.

This function can be enabled or disabled according to requirements.

1) Click the **[Sensor Fault Solution]** to enter its setting interface.

Sensor Fault Solution:

No. 1 Major ID: <input type="text" value="0"/> Related ID: <input type="text" value="0"/>	No. 2 Major ID: <input type="text" value="0"/> Related ID: <input type="text" value="0"/>	No. 3 Major ID: <input type="text" value="0"/> Related ID: <input type="text" value="0"/>	No. 4 Major ID: <input type="text" value="0"/> Related ID: <input type="text" value="0"/>
No. 5 Major ID: <input type="text" value="0"/> Related ID: <input type="text" value="0"/>	No. 6 Major ID: <input type="text" value="0"/> Related ID: <input type="text" value="0"/>	No. 7 Major ID: <input type="text" value="0"/> Related ID: <input type="text" value="0"/>	No. 8 Major ID: <input type="text" value="0"/> Related ID: <input type="text" value="0"/>
No. 9 Major ID: <input type="text" value="0"/> Related ID: <input type="text" value="0"/>	No. 10 Major ID: <input type="text" value="0"/> Related ID: <input type="text" value="0"/>	No. 11 Major ID: <input type="text" value="0"/> Related ID: <input type="text" value="0"/>	No. 12 Major ID: <input type="text" value="0"/> Related ID: <input type="text" value="0"/>
<input checked="" type="checkbox"/> Enable		<input type="checkbox"/> Disable	
<input type="button" value="Quit"/>			

- 2) Set the Major ID and its Related ID. You can set up to 12 pairs.
- 3) Touch the **[Enable]** or **[Disable]** to activate or stop this function.
( blue – unchecked,  green – checked)
- 4) Click **[Quit]** to close the interface.

5.2.11 Speed Related Setting

You can divide all zones into up to 4 groups (max.11 zones in each group, the zones not appointed will be in the last group). The groups will start to work one by one in turn.

When the system starts, the first group will start to work. When each zone's temperature arrives at the target range (the tolerance can be set), the next group will start to work, until all the groups are running.

Typically, the slower heating manifolds should be in the first group and the faster heating nozzles are in the last group.

This function can be enabled or disabled according to requirements.

- 1) Click the **[Speed Related Setting]** to enter its setting interface.

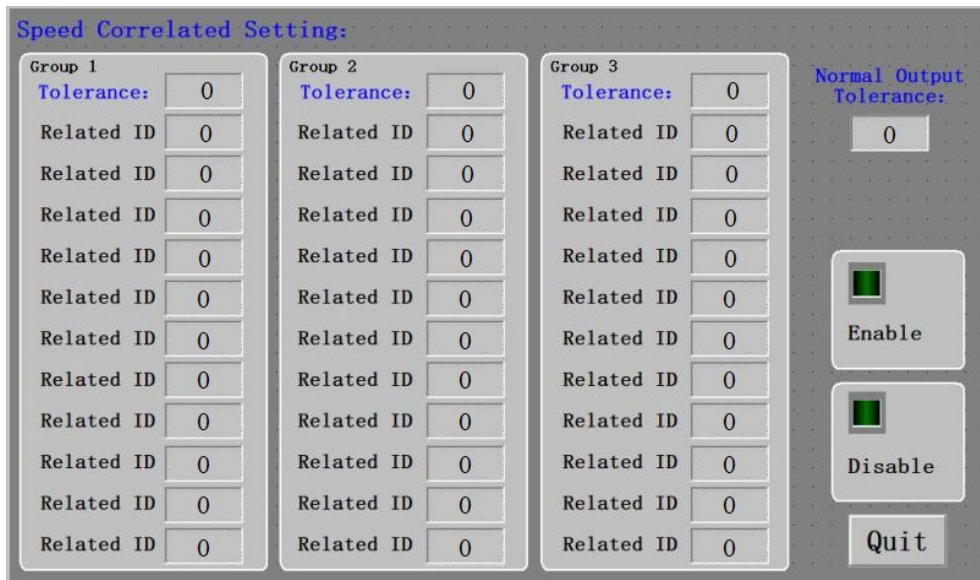



Speed Correlated Setting:

Group 1	Group 2	Group 3	Normal Output Tolerance:
Tolerance: 0	Tolerance: 0	Tolerance: 0	0
Related ID 0	Related ID 0	Related ID 0	<input checked="" type="checkbox"/> Enable <input checked="" type="checkbox"/> Disable <input type="button" value="Quit"/>
Related ID 0	Related ID 0	Related ID 0	
Related ID 0	Related ID 0	Related ID 0	
Related ID 0	Related ID 0	Related ID 0	
Related ID 0	Related ID 0	Related ID 0	
Related ID 0	Related ID 0	Related ID 0	
Related ID 0	Related ID 0	Related ID 0	
Related ID 0	Related ID 0	Related ID 0	
Related ID 0	Related ID 0	Related ID 0	
Related ID 0	Related ID 0	Related ID 0	
Related ID 0	Related ID 0	Related ID 0	
Related ID 0	Related ID 0	Related ID 0	

- 2) Appoint zones for each group.
If you need to divide all zones into 2 groups you can appoint zones for group 1, the remaining zones will be the second group.
- 3) Set the target tolerance for each group.
e.g. If you need the next group will work when each zone's temperature is not less 5 than its target, then you should set the tolerance to 5 for this group.

4) Touch the **[Enable]** or **[Disable]** to start or stop this function.

( blue – unchecked,  green – checked)

5) Click **[Quit]** closing this interface.

- **Normal Output Tolerance:**

Normal output contact will be closed when all zones' temperature are in normal output tolerance.

5.2.12 Help

Touch  **[Help]** to get help on the operation.

5.2.13 Back

Touch  **[Exit]** to go back to the main interface.

5.3 Leakage Detection

Leakage Detection operates by monitoring the power output and creating an alarm if the power output changes by a Leakage Detection tolerance pre-set by the user. Leakage Detection can be accessed for all zones using the Engineer, Director or Admin login and going to the Setting menu > next page > Leakage Detection. For a single zone the Director or Admin login can access by selecting the temperature zone icon button required. By default, a value of 0 is set indicating the Leakage Detection is inactive. To activate select the Leakage Detection box and then in the pop-up box enter a percentage increase value allowable of the operating power.

By default, the operating power is determined automatically by the system, however if required the user can enter a power percentage value for expected Leakage Power use. Leakage Power is set at 0 for automatic, the user can select the Leakage Power box to enter an expected percentage power use, the Leakage Detection percentage will be added onto the Leakage Power value.

Chapter 6 Temperature Control Operations

6.1 Control Modes

[Auto]:

This type of control is a “closed-loop” system and requires a thermocouple feedback signal.

The controller uses a PID algorithm to determine the required output power to hold the actual temperature value equal to the setpoint.

This mode is applied on all zones when the system starts to work.

[Standby]:

This type of control is similar to Auto mode. It is a “closed-loop” system and requires a thermocouple feedback signal.

The controller uses a PID algorithm to determine the required output power to hold the actual temperature value equal to standby temperature value (70% of setpoint).

[Manual]:

This type of control is an “open-loop” system and requires no thermocouple feedback signal.

The controller regulates output power according to the manual setting.

This mode only can be selected by zone setting.

Auto Tune function:

This function is for getting the optimal PID value for a system.

It is a “closed-loop” system and requires a thermocouple feedback signal.

Generally, AT function only needs to be executed when PID factory setting cannot meet the system requirements.

After finished auto tuning, the optimal PID value is saved, and the controller returns to Auto mode.

This function only can be selected by zone setting.

Note: To start PID auto-tuning function, present temperature value should be lower than set point.

Rated Current	Rated load current (Amps). Alarms when the actual load current is over the setting.
Sensor Protection	Misconnection of heater & sensor diagnostic function. 0 – Off. 1 – Checking the heater after power on, if it's judged as sensor, controller will alarm and cut off output to protect it.
Load Check	Diagnostic function for heater. 0 – Off. 1~10 – Checking the load current when output is setting×10%, if the controller judges the heater fault, it will alarm and cut off output. Recommended setting is 3~5.
Max. Current	High limit of load current (Amps). When load current is higher than setting, controller will limit it by decreasing the power output.
Parameter	Description
Filter	To reduce the influence of interference. The larger the value is, the slower the controller responses. When it is too large, the controller may be out of control.
Load-short Sensitivity	Diagnostic sensitivity for load shorted, 0~100. The greater the value is, the lower the sensitivity. Recommended setting is 0.
Slow Heating	Heating speed slowing function. 0 – Off. 1 – On.
Heating Invalid Diagnostic Time	Diagnostic function for heating invalid. 0: Off. 1~999: When output percent is 100%, if the temperature does not rise in setting time (unit: minutes), the controller will alarm and adjust output percent to 0%.
Over-Voltage	Supply voltage high alarm setting, 6~30. When the power supply voltage is over about (setting×4.5+210)V, the controller will alarm and cut off output. Recommended setting is VoL=13 (over-voltage is about 270Vac).
Leakage Power	System steady-state output power percentage value 0: System automatically determines 1~100: Manual setting

Leakage detection	Plastic leakage detection 0: Off 1~100:When output percent is over (Leakage Power + Leakage detection)%,the controller will alarm and show "leakage"
--------------------------	--

6.4 Group Setting & Mold Patterns & Language selection

Touch  **[Group]** on the main interface, and then you can enter the Global Config & Pattern Management Screen.

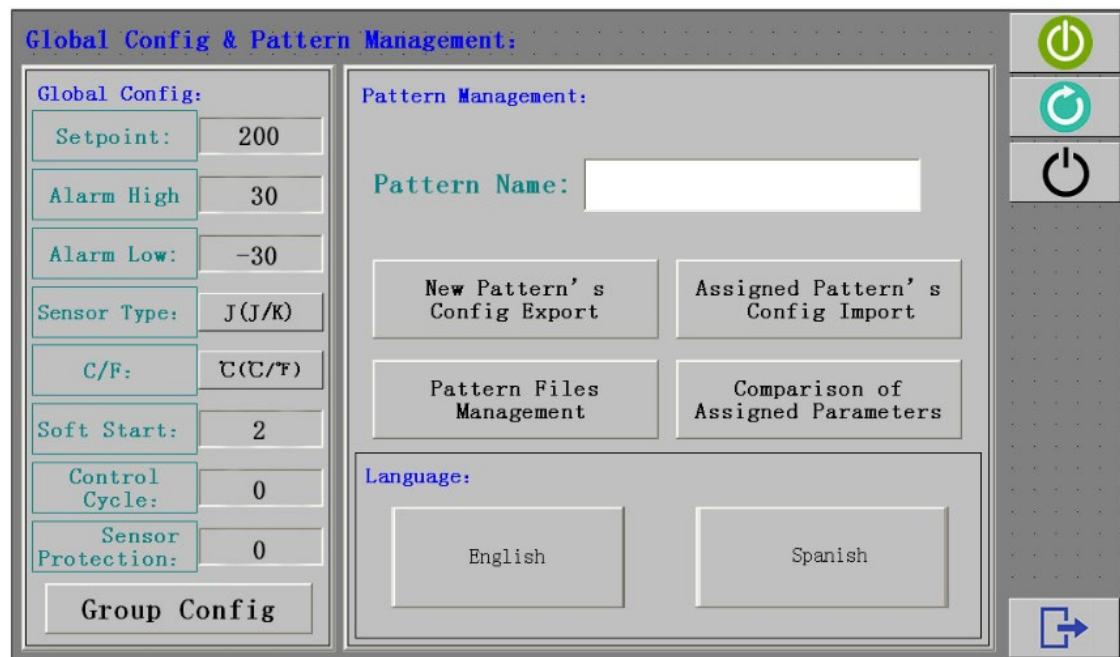

6.4.1 Group Setting

You can change the parameters for all zones (if no zones are selected) or selected zones via Global Config by individual selection, or change parameters for zones with same background color via Group Config by color.

6.4.1.1 Global Config

Parameters for all zones can be set all together.

- 1) Click the parameter value to be set, and then the keyboard will appear.
- 2) Input the required value.
- 3) Click **[OK]** to complete the setting.

NOTE: If there is no response when you click the parameter's value, it means this parameter cannot be changed or the authority security is not enough.

6.4.1.2 Group Config

Parameters for zones with the same background color can be set all together.

Comment: To set the background color of each zone, please refer to 6.5.3

- 1) Click **[Group Config]**, the background color window will appear.
- 2) Select the background color of zones you want to set parameters, the setting page will appear.
In this page the **[Run]** /**[Stop]** button only works for these zones.

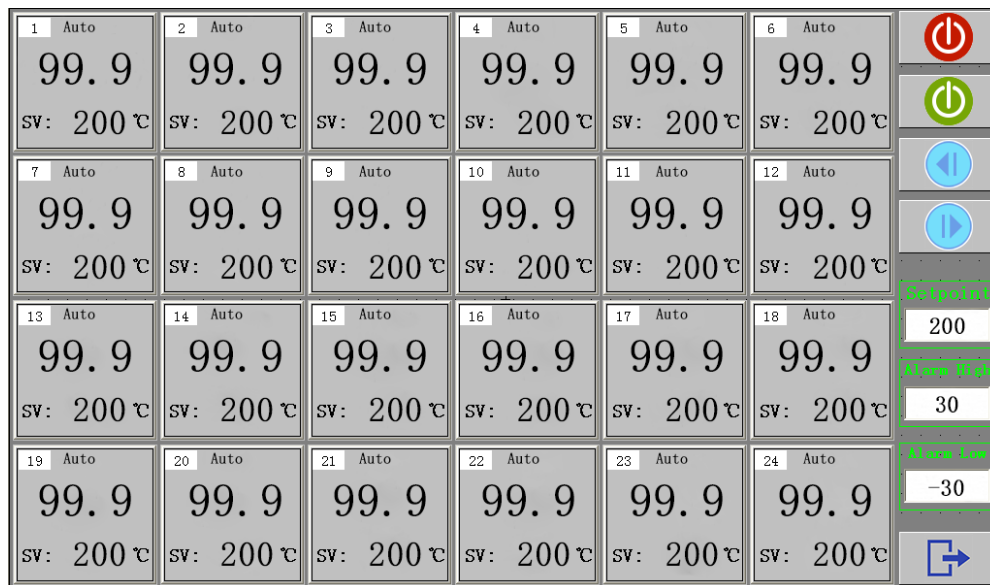

- 3) Click the parameter's value needed to be set, and then the small keyboard will appear.
- 4) Input the required value.
- 5) Click **[OK]** to complete the setting.

NOTE: If there is no response when you click the parameter's value, it means this parameter cannot be changed or the authority is not enough.

6.4.2 Mold Patterns

You can manage the mold patterns by **Pattern Management**.

CTI can save a maximum of 72 sets of mold parameters to the local memory, as well as to USB disk.

You can import, export, and delete the pattern files, etc.

NOTE: The mold pattern file is a database file containing the control parameters of each zone.

6.4.2.1 New Pattern's Config Export

1. Enter a new Pattern Name in the box.
2. Click the **[New Pattern's Config Export]** to save the settings of current online modules. Zones' On/Off state, auto/manual control mode, and the background color will be also saved in the pattern file.

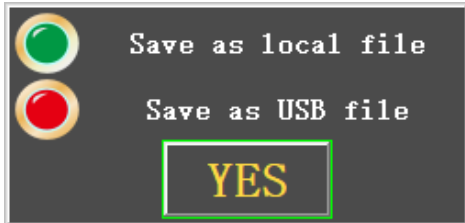

NAME PATTERN CAREFULLY!

If the name of the new pattern is same as an existing pattern, the original file will be over-written by the new one.

6.4.2.2 Assigned Pattern's Config Import

1. Click the **[Assigned Pattern's Config Import]** to enter the pattern files selected screen.



1. Click **USB File** to display USB files or local files, Select pattern file needed to use click selector,  means selected.
2. Click **[OK]** to import the parameters in the pattern file to the online modules. The system will generate a report at the end of importing process.
3. Click **[QUIT]** on the report page to close it.

4. Click **[QUIT]** to back the Global Config & Pattern Management Screen.

All zones will work on new imported settings, and the pattern name will be showed in the status bar.

6.4.2.3 Pattern Files Management

Click the **[Pattern Files Management]** to enter the management screen.

You can browse the pattern files stored in a USB disk or in the local storage and manage these files.

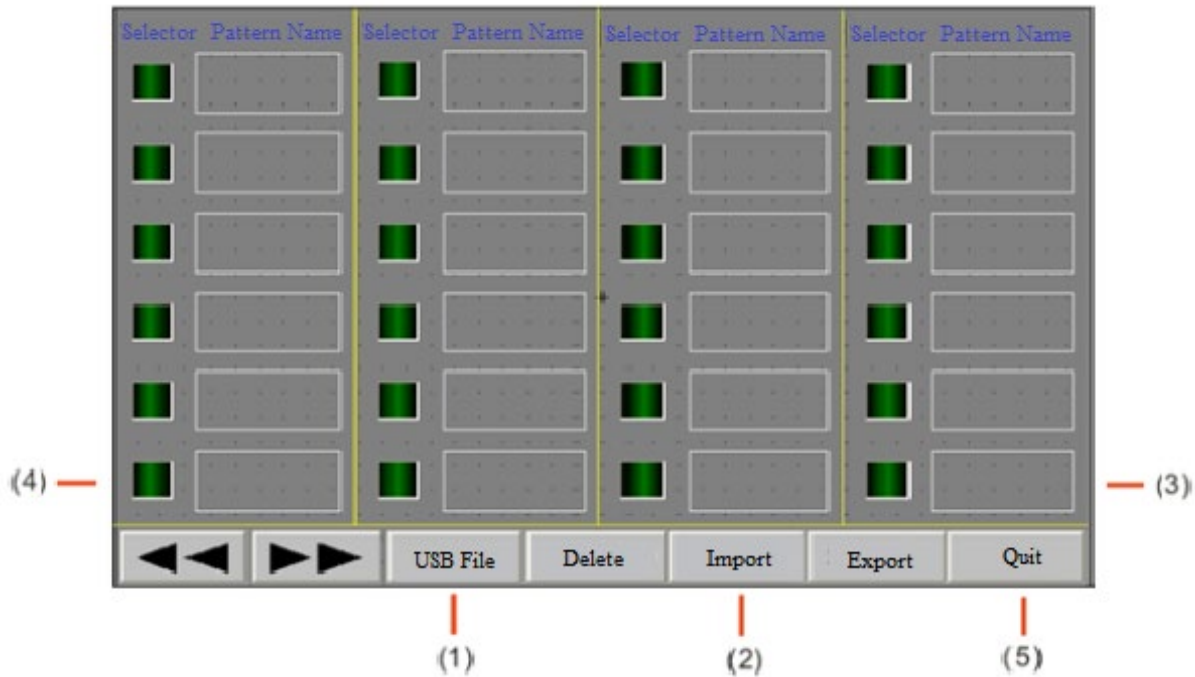

- 1) File location selected: **[Local File]** or **[USB File]**.
- 2) **[Delete]**: to delete the selected file;
[Import]: to import the files selected from the USB disk to the local storage.
[Export]: to export the files selected from the local storage to the USB disk.
- 3) Pattern Name.
- 4) Pattern selector & indicator:
 Red – unchecked, green – checked.
- 5) **[Quit]**: back to the Global Config & Pattern Management Screen.

6.4.2.4 Online Browsing and Modify Pattern Data

You can browse the ID number and all parameters of each zone. When you click a parameter, the parameter changes to yellow filled background (other parameters in the same zone change to blue background). Click the parameter again to bring up small keyboard to modify it.

Num	Name	SV	ALH	ALL	Sn	C/F	Set	T	Pi	P	I	D
0	ID1	200.000	30.000	-30.000	0.000	0.000	2.000	1.000	5.000	9.000	160.000	20.000
1	ID2	200.000	30.000	-30.000	0.000	0.000	2.000	1.000	5.000	9.000	160.000	20.000
2	ID3	200.000	30.000	-30.000	0.000	0.000	2.000	1.000	5.000	9.000	160.000	20.000
3	ID4	200.000	30.000	-30.000	0.000	0.000	2.000	1.000	5.000	9.000	160.000	20.000
4	ID5	200.000	30.000	-30.000	0.000	0.000	2.000	1.000	5.000	9.000	160.000	20.000
5	ID6	200.000	30.000	-30.000	0.000	0.000	2.000	1.000	5.000	9.000	160.000	20.000
6	ID7	200.000	30.000	-30.000	0.000	0.000	2.000	1.000	5.000	9.000	160.000	20.000
7	ID8	200.000	30.000	-30.000	0.000	0.000	2.000	1.000	5.000	9.000	160.000	20.000
8	ID9	200.000	30.000	-30.000	0.000	0.000	2.000	1.000	5.000	9.000	160.000	20.000
9	ID10	200.000	30.000	-30.000	0.000	0.000	2.000	1.000	5.000	9.000	160.000	20.000
10	ID11	200.000	30.000	-30.000	0.000	0.000	2.000	1.000	5.000	9.000	160.000	20.000
11	ID12	200.000	30.000	-30.000	0.000	0.000	2.000	1.000	5.000	9.000	160.000	20.000
12	ID13	200.000	30.000	-30.000	0.000	0.000	2.000	1.000	5.000	9.000	160.000	20.000
13	ID14	200.000	30.000	-30.000	0.000	0.000	2.000	1.000	5.000	9.000	160.000	20.000
14	ID15	200.000	30.000	-30.000	0.000	0.000	2.000	1.000	5.000	9.000	160.000	20.000
15	ID16	200.000	30.000	-30.000	0.000	0.000	2.000	1.000	5.000	9.000	160.000	20.000
16	ID17	200.000	30.000	-30.000	0.000	0.000	2.000	1.000	5.000	9.000	160.000	20.000
17	ID18	200.000	30.000	-30.000	0.000	0.000	2.000	1.000	5.000	9.000	160.000	20.000

Parameters Setting: Pattern Name : A Save Quit

6.4.2.5 Comparison of Assigned Parameters

1. Enter the Pattern Name that needs to be compared.
2. Click the [Comparison of Assigned Parameters] to compare the parameters of the online modules with the parameters of the pattern file.

6.4.3 Language

You can change language by touch the related language button.

NOTE: You need to re-start HMI after changing the language, or some functions maybe abnormal.

6.4.4 Back

Touch  [Exit] to go back the main interface.

6.5 Zone Setting

Touch the Actual Temperature on the main interface, then enter Zone Parameters Setting Screen (different authority can see different parameters).

6.5.1 Operator-Login Status



- Change Setting Value: by [<] [^] [v]
- Save Setting Value: click [SET]
- Run or Stop this zone: click [Run] / [Stop]

6.5.2 Engineer-Login Status

- **Change Setting value:** click it to call up small keyboard.
- **Run or Stop this zone:** click **[Run]**/**[Stop]**.
- **Change Control mode of this zone:** click **[Auto]** or **[Manual]**, and then confirm it.
- **Set power output percent in Manual mode:** click it to call up small keyboard.
- **Back to main interface:** click **[Quit]**.

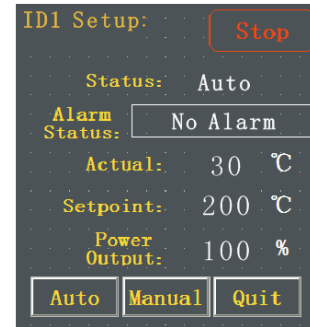

6.5.3 Engineer or Administrator Login Status

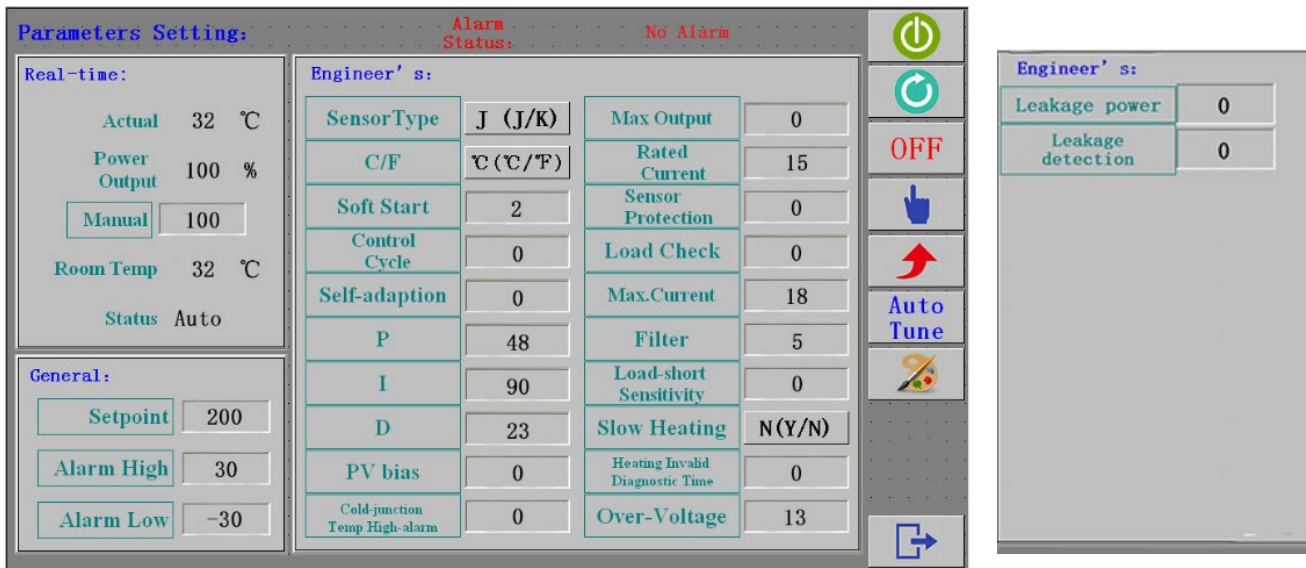

- **Change ID Name:** click it to call up small keyboard and edit the ID name as required
- **Change General and Special parameters:** click Parameter to call up small keyboard.
- **Set output percent in Manual mode:** click the value of **Manual** to call up small keyboard.
- **Run or Stop this zone:** click **[Run]** / **[Stop]**.
- **Turn off or turn on this zone:** click **[OFF]** / **[ON]**
- **Change Control mode of this zone (in running state):** click **[Auto]** or **[Manual]**.
- **Activate Boost function (fast heating speed):** touch **[Boost]**, and the power output percent will be added 20% (max.100%) for 15s.
- **Start Auto-Tune this zone:** click **[Auto Tune]**.
- **Select background color for this zone:** click **[Color]**
- **Back to main interface:** click **[Exit]**

6.6 Graph Display

Touch  **[Graph]** on the main interface to enter the Present Curve Display Screen.

6.6.1 Present Curve (real-time)

You can select 6 zones to view the real-time curve.

And you can touch  **[History]** on this screen to enter the History Curve Display.

And you can touch  **[Exit]** to go back to the main interface.

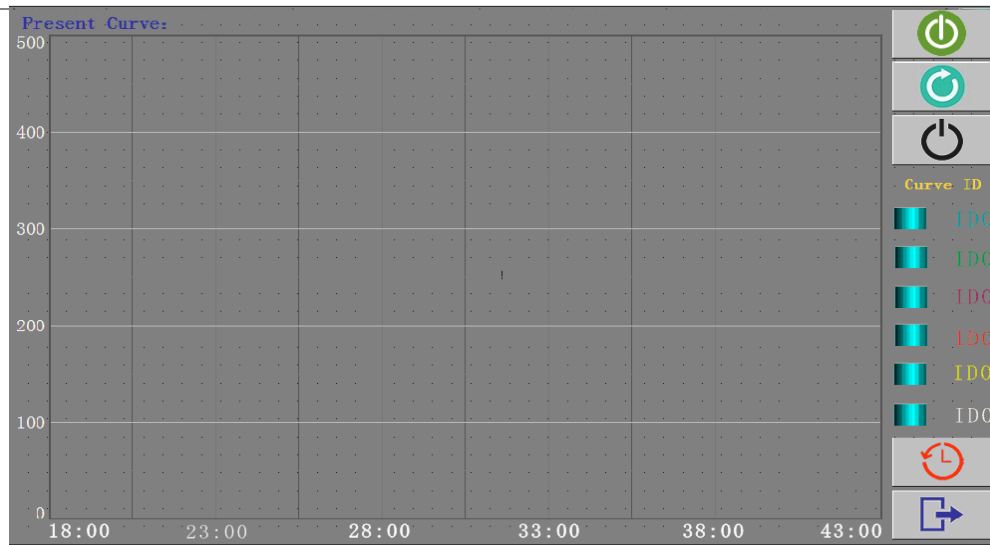

6.6.1.1 Select Zone ID to View

On Present Curve Screen, you can view max. 6 zones.

- 1) Click the ID number to enter curve's ID selection mode.
- 2) Input the ID number which you want to view the curve, and then click **[YES]** to confirm.

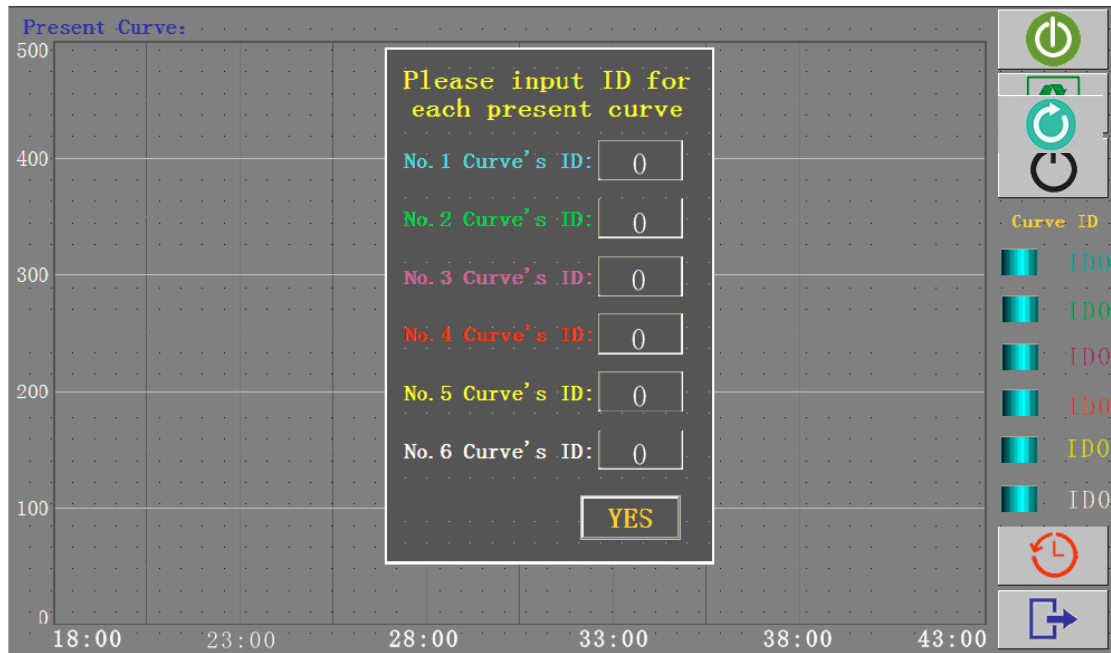

6.6.1.2 Select the Curve Display

The box before the ID number is used to select the curve display.

You can click it. red- unchecked, green - checked.

The curve's color is same as the color of ID number.

6.6.2 History Curve

The system default setting is not saving the temperature data. If you need to review the history curve or export the history data, you should set the Saved Interval time in System Setting.

The system can save the temperature data in the latest 15~30 days.

6.6.2.1 Select Zone ID to View

When you touch  **[History]** on present curve screen, History Curve ID Selection interface will be displayed.

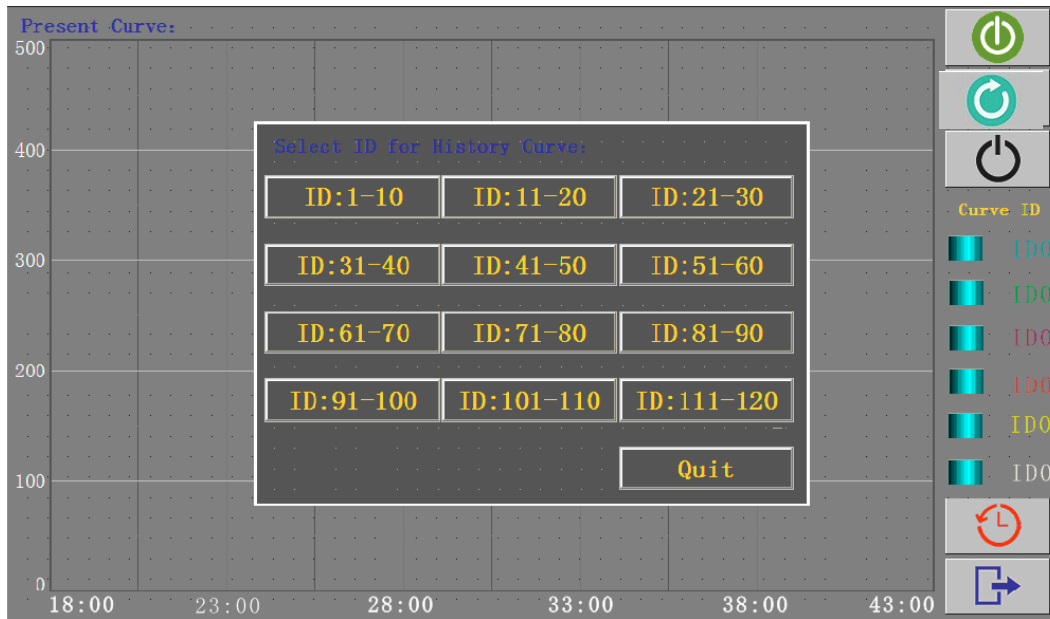

Each History Curve Screen can display 10 zones.
 You can select the ID group to view, or back to present curve by **[Quit]** .

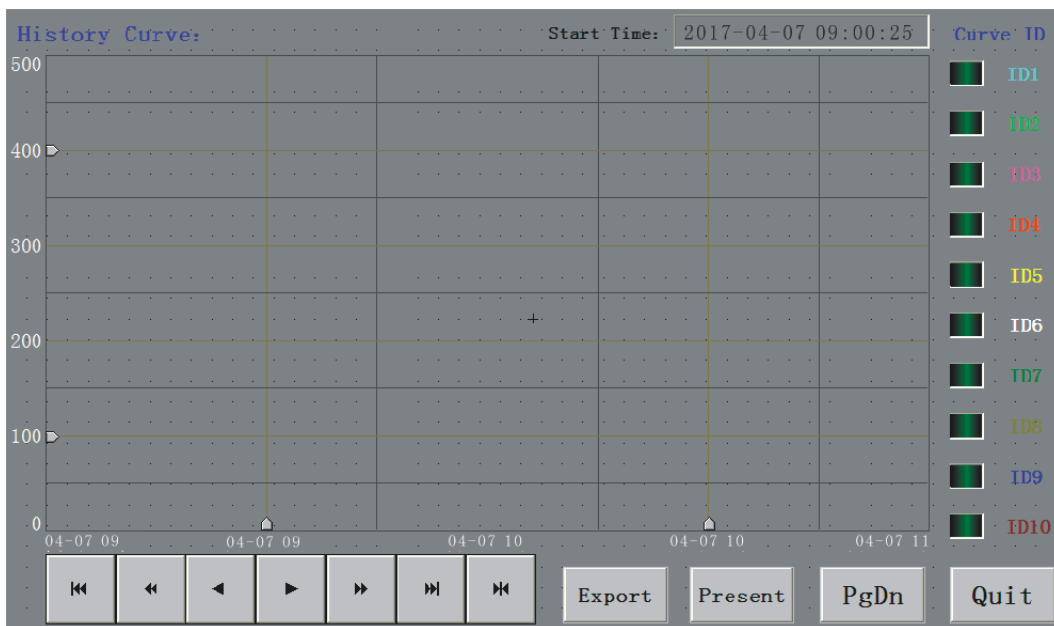

6.6.2.2 Select the Curve Display

The box before the ID number is used to select the curve display.

You can click it. red- unchecked, green - checked.

The curve's color is same as the color of ID number.







6.6.2.3 Select the Curve Start Time

When you enter the History Curve Screen, the curve start time is 2 hours ago.

You can click the **Start Time** to input a new one (the time format should be same as the original one).

And you can select the start time by



	Select a specified time.		
	Forward 0.5 hour based on the curve		Backward 0.5 hour based on the curve
	Forward 1.0 hour based on the curve		Backward 1.0 hour based on the curve
	Forward 2.0 hour based on the curve		Backward 2.0 hour based on the curve

6.6.2.4 Zoom In & Zoom Out the Curve

You can adjust the scale of X/Y axis with the sliding bar, to zoom in or zoom out the curve.

6.6.2.5 View Other Zones

You can view the history curve of other zones by touching **[PgDn]** or **[PgUp]**.

In the first page, you will see the **[Present]** used to back to present curve screen.

6.6.2.6 Export the Historical Data

You can export the historical data record (in csv format) to USB disk by touching **[Export]**.

Notes:

Only supports USB disks that use a File Allocation Table (FAT or FAT32) format.

Only supports USB versions 2.0 and 1.1.

Use an empty USB disk or one that contain as few files as possible.

Do not remove the USB disk from the system during the writing operation.

6.6.2.7 Back to Present Curve

Touch the **[Quit]** to go back to the present curve screen.

6.7.3 Alarm Status

Alarm on Zone	Alarm on Alarm History	Remark
T/C Broken	Thermocouple is broken or damaged	Controller will shut off the output. Check the sensor or switch to manual mode
T/C Reversed	Thermocouple is reversed.	Controller will shut off the output. Check the sensor or switch to manual mode.
T/C Error	Sensor is connected to controller's output terminals.	Related to parameter "Sensor Protection". Controller will shut off the output. Check the wiring. <i>It may cause a false alarm if the heater's power is large.</i>
Over Temp	PV is over high alarm value.	Alarm value = Setting value + Alarm High. Controller will shut off the output. Check the controller & the sensor.
Under Temp	PV is under low alarm value.	Alarm value = Setting value + Alarm Low. Check the system thermal insulation. Or switch to manual mode.
Load Broken	No heater is detected.	Related to parameter "Load Check". Controller will shut off the output. Check the heater.
Load Shorted	Heater is shorted.	Related to parameter "Load-short Sensitivity". Controller will shut off the output. Check the heater.
Triac	Triac is damaged or out of control.	Controller will shut off the output. Check the triac.
Overload	Load current is over rated.	Related to parameter "Rated Current". Check the heater and the Rated current setting.
Fuse blown	Fuse is blown out.	Check the heater and replace the fuse.

Alarm on Zone	Alarm on Alarm History	Remark
Heating invalid	Heater is working, but temperature does not rise.	Related to parameter "Heating Invalid Diagnostic Time". Controller will adjust output percent to 0. Check the sensor and its position.
Temp. twinkling	Communication between HMI and control module is failed	Check the module and communication wiring.
Over Voltage	Supply voltage is over alarm setting.	Related to parameter "Over-Voltage". Check the power supply.
Over Tamb	Cold-junction Temperature is over alarm setting.	Related to parameter "Cold-junction Temp High-alarm". Check the module and the fans of mainframe.
Leakage	Mold Plastic leakage	Related to parameters "Leakage power" and "Leakage detection". Check the injection mold.

Chapter 7 Sequential Valve Gate Control Operations

Touch  [SVG] on Temperature Control main interface, then you can enter Sequential Valve Gate Control main interface.

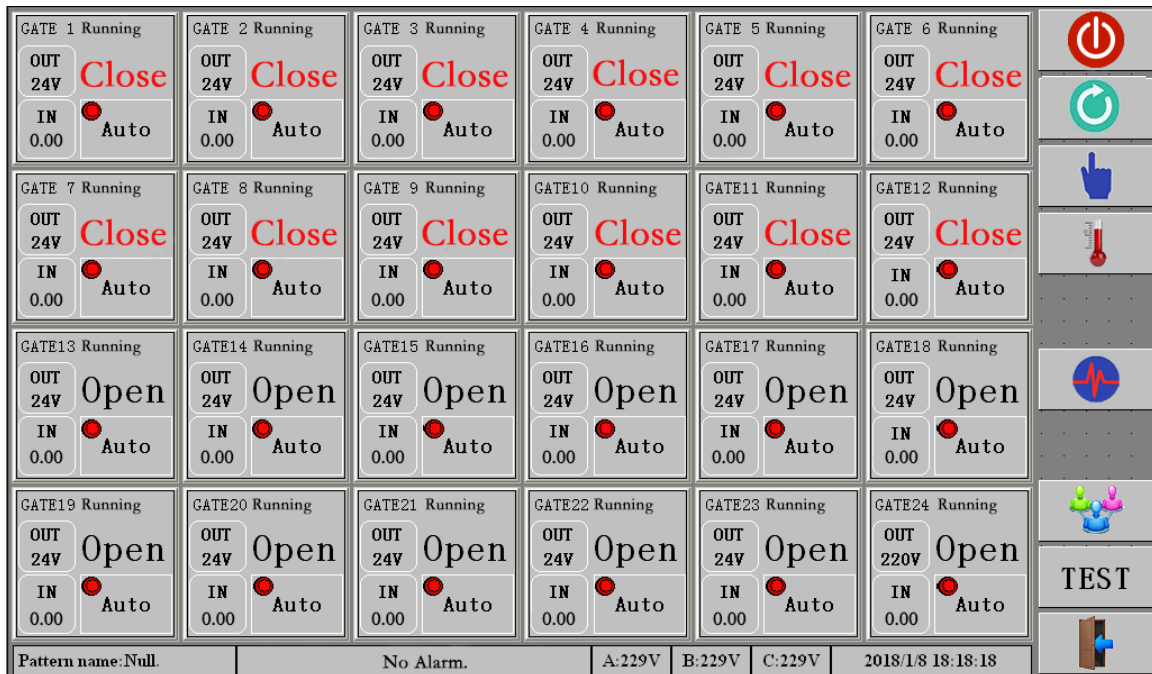

And touch  [Temp] on Sequential Valve Gate Control main interface, then you can enter Temperature Control main interface.

Notes: 1) Zone's output type is selected on modules with jumpers.

2) Input Screw position unit can be mm or inch, selected in screw position's setup (calibration).

7.1 Control Modes

 [Auto]:

This type of control is an auto system and requires a start trigger signal.

The controller will wait until it receives the start trigger after which it starts the timer from zero time position. From this point gates open and close according to the time or position settings that you have configured.

 [Manual]:

This type of control requires no start trigger signal.

Each gate can be opened or closed by touching [MANUAL].

7.2 Start Trigger Modes

This Sequential Valve Gate controller supports gates open/close 1~2 times in a complete cycle.

If the start trigger duration time is longer than a complete cycle of gate open/close, then the control process is:

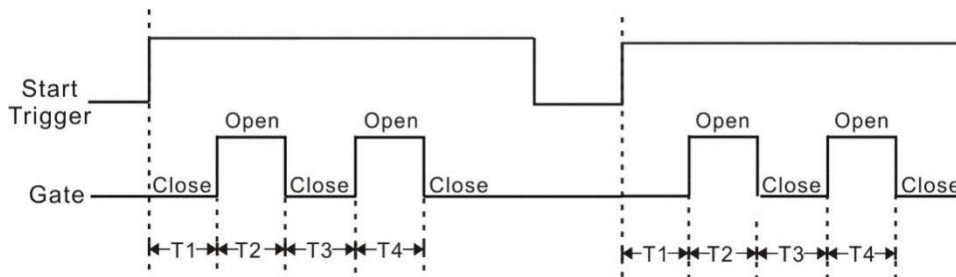

- 1) When the controller receives the start trigger, it starts the timer from the zero time position.
- 2) Gates open after T1 time (or screw position is T1) from the controller receives start trigger;
- 3) Gates close after T2 time (or screw position is T2) from the gates open;
- 4) Gates open again after T3 time (or screw position is T3) from the gates close;
- 5) Gates close after T4 time (or screw position is T4) from the gates open;
- 6) The controller waits a new start trigger.

If the start trigger time of duration is shorter than a complete cycle of gate open/close, then the control process has 4 modes selected by parameter "Input Type".:

Mode 0: Once the gate open/close cycle starts, it will ignore the new start trigger until the cycle ends.

The control process is similar to the start trigger time of duration is longer than a complete cycle of gate open/close.

Mode 0 (Input Type=0)

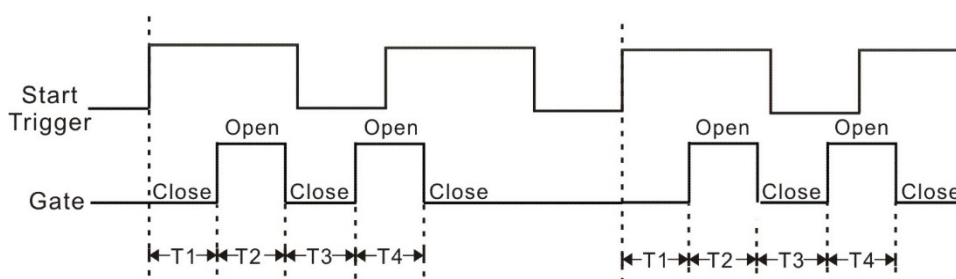

- 1) When the controller receives the start trigger, it starts the timer from the zero time position.
- 2) Gates open after T1 time (or screw position is T1) from the controller receives start trigger;
- 3) Gates close after T2 time (or screw position is T2) from the gates open;
- 4) Gates open again after T3 time (or screw position is T3) from the gates close;
- 5) Gates close after T4 time (or screw position is T4) from the gates open;
- 6) The controller waits a new start trigger.

Mode 1: The gate open/close cycle will be terminated and gate close when the start trigger ends.

The controller initializes the run timer when it receives the new start trigger.

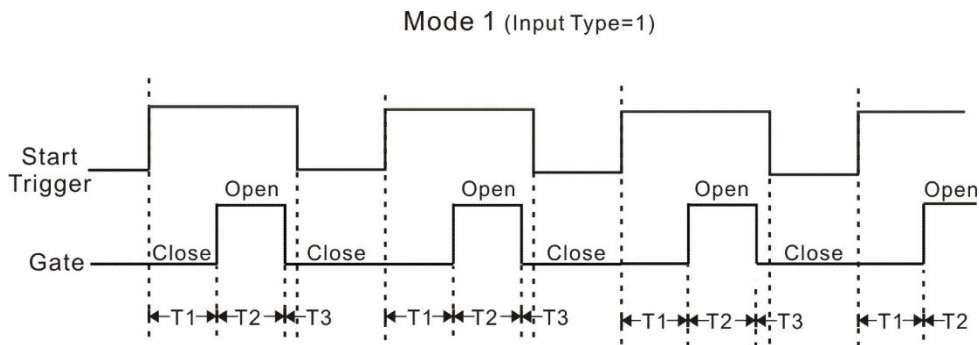

- 1) When the controller receives the start trigger, it starts the timer from the zero time position.
- 2) Gates open after T1 time (or screw position is T1) from the controller receives start trigger;
- 3) Gates close after T2 time (or screw position is T2) from the gates open;
- 4) Gates open again after T3 time (or screw position is T3) from the gates close;
- 5) Gates close after T4 time (or screw position is T4) from the gates open;
- 6) In the control process, when the start trigger ends, the gate open/close cycle will be terminated and gate close.
- 7) The controller waits a new start trigger.

Mode 2: The gate open/close cycle will be terminated and gate close when the new start trigger comes.

The controller initializes the run timer when it receives the new start trigger.

Mode 2 (Input Type=2)

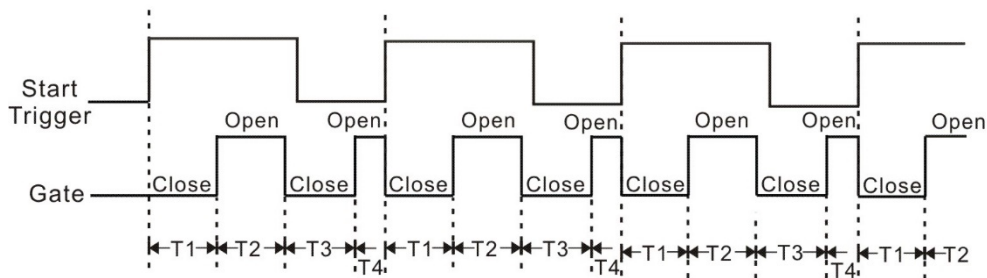

- 1) When the controller receives the start trigger, it starts the run timer from the zero time position.
- 2) Gates open after T1 time (or screw position is T1) from the controller receives start trigger;
- 3) Gates close after T2 time (or screw position is T2) from the gates open;
- 4) Gates open again after T3 time (or screw position is T3) from the gates close;
- 5) Gates close after T4 time (or screw position is T4) from the gates open;
- 6) In the control process, when the new start trigger comes, the gate open/close cycle will be terminated and gate close.

At the same time, the controller initializes the run timer to start a new gate open/close cycle.

Mode 3: The gate open/close cycle will be terminated and gate close when the new start trigger comes.

The controller initializes the run timer when it receives the next new start trigger.

Mode 3 (Input Type=3)

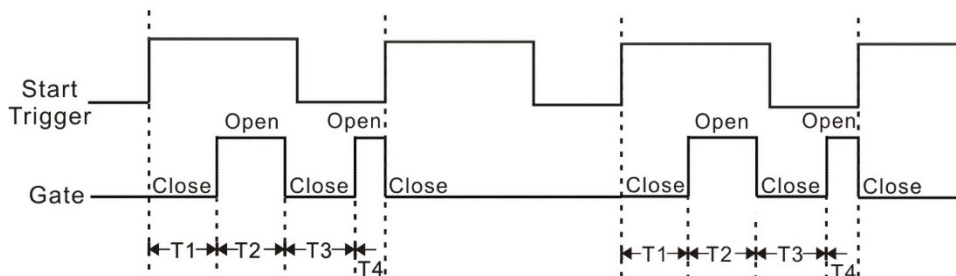

- 1) When the controller receives the start trigger, it starts the run timer from the zero time position.
- 2) Gates open after T1 time (or screw position is T1) from the controller receives start trigger;
- 3) Gates close after T2 time (or screw position is T2) from the gates open;

- 4) Gates open again after T3 time (or screw position is T3) from the gates close;
- 5) Gates close after T4 time (or screw position is T4) from the gates open;
- 6) In the control process, when the new start trigger comes, the gate open/close cycle will be terminated and gate close.
- 7) The controller waits the next new start trigger.

7.3 Gate Open/Close Trigger Modes

You have two main options that you can use to set up gate opening and gate closing times.

- 1) **Time value only** – you can open and close the gate using a timer.
- 2) **Screw Position** (and time) – if you have position sensors that detect screw ram position and feed it back via an analogue (0~10Vdc) input, then you can set gate open and close relative to screw position. You can also use a combination of screw position and time.

7.4 Detail Parameters for Each Gate

Parameter	Description
T 1	Gate open delay time (or screw position) from the controller receives start trigger.
T 2	Gate open duration time (or screw position for gate closing).
T 3	Gate open again delay time (or screw position) from it close.
T 4	Gate open duration time (or screw position for gate closing).
Input Filter	Filter for start trigger, used to reduce the influence of interference. When it is too large, the controller cannot work normally.
Input Type	Start trigger modes selection.
Resolution	Resolution for Time (sec) / Screw position (mm/inch)

7.5 Gate Setup

Touch the Gate Status “Open” or “Close” on the main interface, then you can enter Gate Setup Screen (different authority can see different parameters, and no parameter can be seen without login).

7.5.1 Operators-Login Status

- **Set T1 ~T4:**
click the value to call up small keyboard.
- **Back to main interface:** touch [Quit].

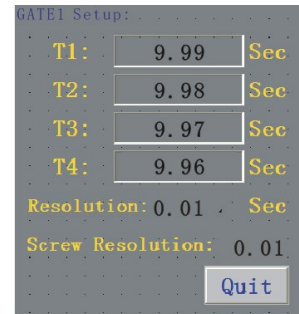

7.5.2 Engineers or Administrators Login Status

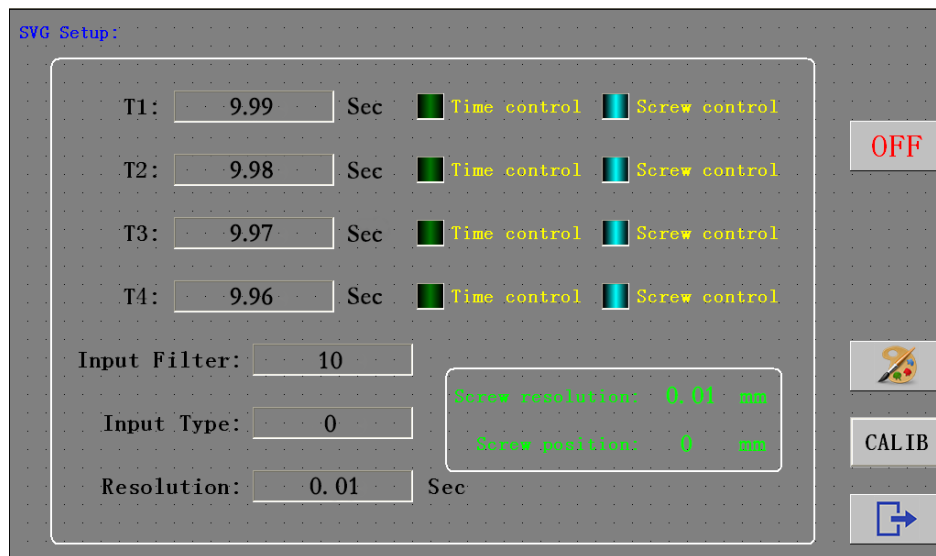

- **Screw Position Setup:** touch **CALIB** to call up screw position setup screen.

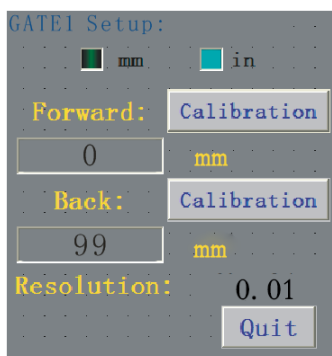

- 1) **Select screw position unit:** mm or inch, the green means selected.
- 2) **Set screw position resolution:** click the value to call up small keyboard, set 0.01, 0.1 or 1.
- 3) **Set screw forward & back position:** click the value to call up small keyboard.
- 4) **Calibrate screw forward & back position:** push the screw to forward position and touch [Calibration] forward; next push the screw to its back position and touch [Calibration] back.



You can repeat calibration if you feel that either position was incorrect.

When you are satisfied that all is good, touch **[Quit]** to set the figures and leave the screen.

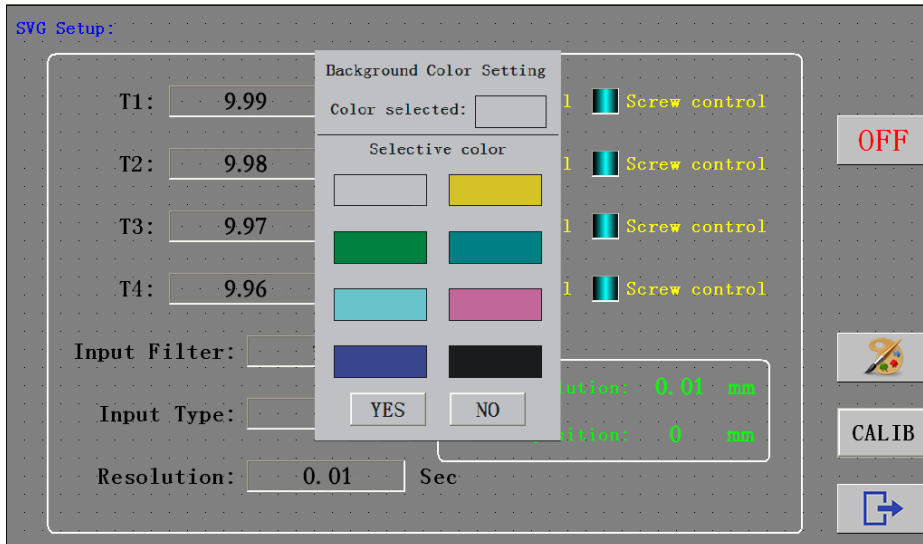
- **Select background color of this gate:** touch  **[Color]** to call up background color setting.



Select a color you want to use as background of this gate, and then click **[YES]** to set the figures and leave the screen.

- **Turn off or turn on this zone:** touch **[OFF]** / **[ON]**
- **Set input filter:** click the value to call up small keyboard.
- **Set input type:** click the value to call up small keyboard.
- **Set time resolution:** click the value to call up small keyboard, set 0.01, 0.1 or 1.
- **Select gate open/close trigger modes:**
click the indicator of Time control or Screw control to select modes for T1~T4.
 blue - unchecked,  green - checked.
- **Set T1~T4:** click the value to call up small keyboard.
- **Back to main interface:** touch  **[Exit]**.

7.6 Preview the Setting

Touch  **[Graph]** on the main interface, and then you can see the sequential chart of all gates

open/close setting. You can compare and confirm the setting.

7.7 Test

Touch  [Test] on the main interface to reverse the open/closing status of all valves during manual control. The one that was originally opened becomes closed, and the one that was originally closed becomes opened.

Chapter 8 Run/Stop System

8.1 Run System

Touch  [Run] on the main interface of temperature control or Sequential Valve Gate control to run the system.

Temperature Control

All zones start to work in Auto mode (disable keep the data in system setting) or the mode before power off (enable keep the data in system setting) except the module is turned off by zone setting.

- You can touch  [Standby] on the main interface to make all zones work in Standby mode.
- You can make a specified zone work in Standby mode by Zone Setting.
- You can make a specified zone work in Manual mode and set its power output by Zone Setting.
- You can Run or Stop a specified zone by Zone Setting.
- You can activate Boost or Auto-Tune function for a specified zone by Zone Setting.
- You can Run or Stop a group of zones with the same background color by Global Config.

Note:

(1) In a single temperature zone setting, each temperature zone can be started or stopped individually.

(2) In the group setting, you can start or stop temperature zones in groups according to same background color

(3) In the main control interface, click the run/stop button  of a temperature zone to independently run or stop this temperature zone.

(4) After selecting multiple temperature zones on the main control interface, click  [Run] to start only the selected temperature zones.

Sequential Valve Gate Control

All zones start to work in Auto mode.



You can touch  **[Manual]** on the main interface to make all zones work in Manual mode.

In Manual mode, you can open or close each gate by touching **[Manual]**.

8.2 Stop System

Touch  **[Stop]** on the main interface of temperature control or Sequential Valve Gate control to stop the system.

All modules stop working.

- You can Stop a specified zone by Zone Setting.
- You can Stop a group of zones with the same background color by Global Config.
- Clicks the start/stop button  of a temperature zone on the main control interface to stop the temperature zone individually.
- After selecting multiple temperature zones on the main control interface, click  **[Stop]** to stop only the selected temperature zone.